

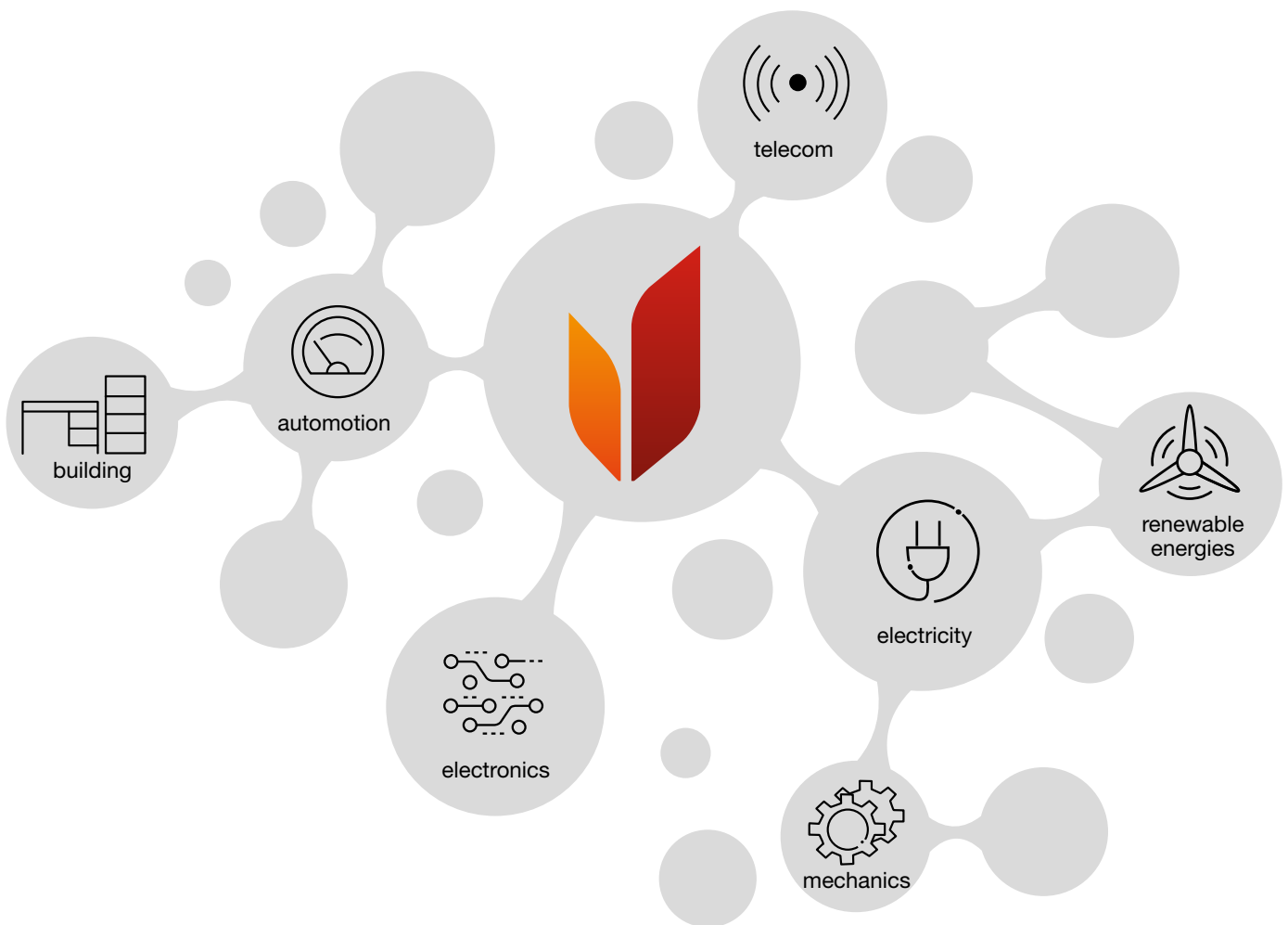

We provide **integral equipment**

Alecop designs, develops and manufactures technical training equipment for engineers and technicians. Our customers range from universities and colleges to schools and industrial training centres in all the continents of the world.

Alecop products cover electrical engineering, renewable energy, automotive technology, manufacturing systems and telecommunications. We believe in hands-on training systems which can be enhanced and complemented by our software tools which provide simulation, curriculum material and classroom solutions.



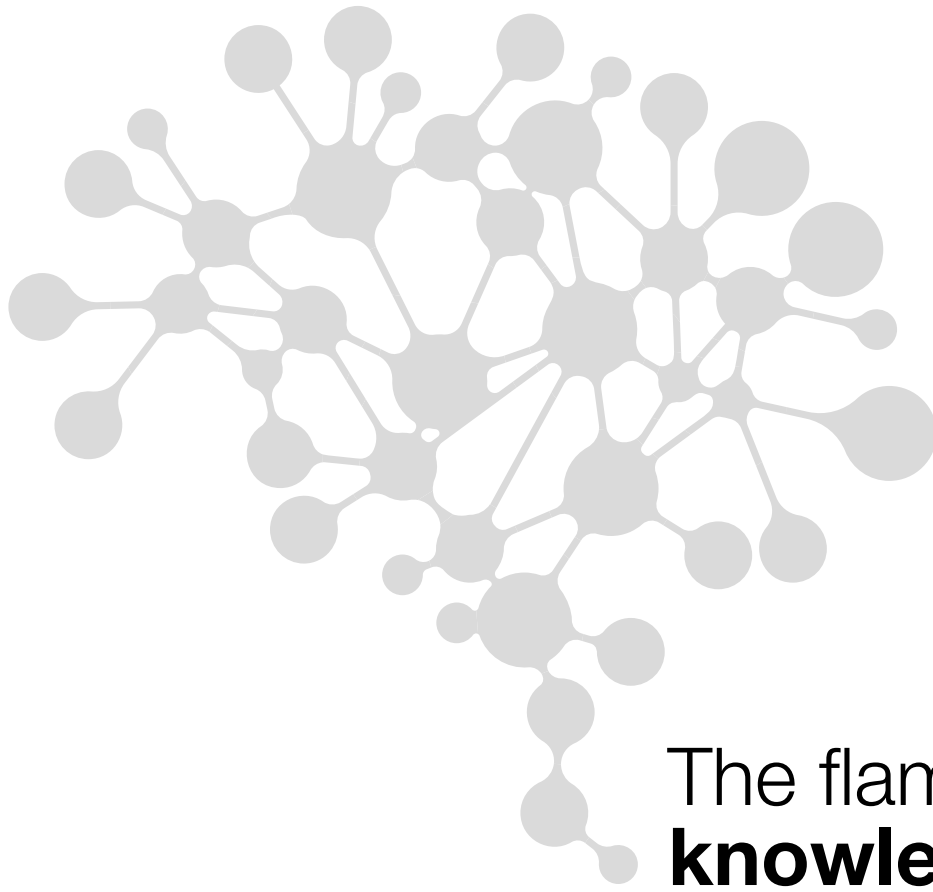

The flame of **knowledge**

In addition, Alecop is involved in the management of training establishments in many countries and the development of curriculum and training material. This intimate knowledge of education and the challenges facing educators in the 21st century allows us to develop exclusive turnkey solutions which are cost effective, scalable and innovative.

Uniquely Alecop's mission statement is to develop a bridge between training and industry to equip students with the necessary skills and knowledge they need before they start their professional careers.

Alecop is a part of the Mondragon Corporation which is one of the most important business groups in Spain. From its headquarters in the Basque country Mondragon manages more than 240 companies in more than 14 countries and a workforce of approximately 81,000.

1. AUTOMOTIVE 6

· ADA Series	
Electricity and Electronics	6
- ADA-300	
Application of Electricity	8
- ADA-301	
Application of Electronics	10
- ADA-303	
Application of Sensors	12
- ADA-304	
Electronic Control Unit	14
- ADA-305	
Actuator applications	16
- ADA Engine	18
- ADA-306	
Multiplexed CAN-LIN buses	20
- ADA-307	
Hybrid Vehicle application	22
- ADA-308	
Electric Vehicle application	24

2. MECHANICAL MANUFACTURING 26

· Introduction	26
· PC controlled CNC Machines	28
- Atenea.	
CNC machining centre with integrated PC control	28
- Hermes.	
CNC lathe with integrated PC control	30
· CNC programming and control emulation	32
- WinUnisoft ⁺	
Programming, simulation and control of machines	32
· Virtual machines	37
- Virtool.	
Interactive virtual environment	37
· Plastic injection machine	41
- Babyplast.	
Plastics injection machine	41
· Assembly and mechanical maintenance	43

3. ELECTRICAL ENGINEERING 44

· Introduction	44
· ANG-800 didactic equipment for circuit analysis	46
· Electrostatics and electromagnetism	48
· Three-phase systems	50
· Transformers	52

4. ELECTRICAL MACHINES 54

· Introduction	54
· ProLAB - Modular Test Bench	56
- Independent bench for testing rotating electrical machines	60
- 199 series modules	61
- SAD450M Module	67
- DIANA Software - machine control and simulation	68
· CM-281 Automation	70
· Educational Transformers	73
· KMQ120 kit of rotary electric machines	74
· KMQ100 basic kit of rotary electric machines	76
· AC & DC Electrical machines	78

5. ELECTRONICS AND COMMUNICATIONS 80

· 800 series	80
- ANG-800 console: Analog electricity and electronics	81
- DIG-800 console: Digital electronics	85

6. POWER ELECTRONICS 86

- **Introduction** 86
- **Modular system** 88
 - EP1/EP2 - Controlled and uncontrolled rectification 88
 - EP3 - Switching power devices 90
 - EP4/EP5 - DC/DC and DC/AC converters, choppers and inverters 92
 - EP6 - Speed and current regulation accessories 94
 - Assembly and power supply system 95
- **Electronic control of electrical machines** 96
 - RMCC-900 DC - Electronic speed regulation of DC SCR motors 98
 - RMCA-900 AC - Electronic speed regulation of alternating current motors 100
 - RMBR-900 - Electronic regulation of Brushless motor speed 102
- **Electrical machines and braking systems** 104

8. RENEWABLE ENERGY 120

- **Solar photovoltaic** 120
 - EN106. Computerized photovoltaic installation demonstrator 120
 - EN044. Insulated wind power plant trainer 122
 - EN042. Grid connected windmill energy plant trainer 124
 - EN041. Windmill test-bench 126
 - EN051. Hydroelectric plant with Pelton turbine 128
 - FLO31. Series and Parallel Pumps 130
 - AC031. Heat Pump Demonstration 132

7. REGULATION AND CONTROL SYSTEMS 106

- **Introduction** 106
- **540 series** 108
 - Study of speed and position control processes 108
 - Study of temperature control processes 110
 - Study of level processes and flow 112
 - Study of physical magnitude sensors 114
- **DAQ-601.** Control module by Matlab/Labview 116
- **Kaptoris.** Data acquisition system 118

9. TECHNICAL FURNITURE 134

- **Introduction** 138
- **Standard line** 136
- **Customised designs** 139

ELECTRICITY ELECTRONICS - ADA SERIES

The ADA series of self-contained training modules covers all aspects of electronic and electrical circuits and systems used on modern automobiles.



ADA 300: electricity application

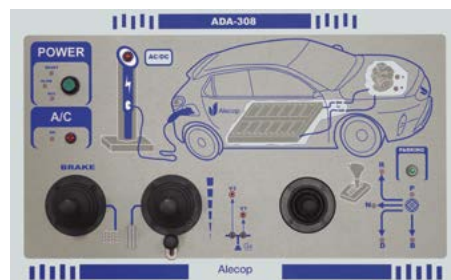

ADA 308: electric vehicle application



ADA 307: hybrid vehicle application

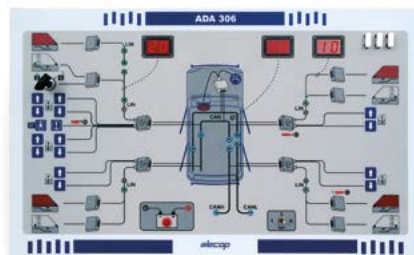

ADA 306: multiplexed CAN-LIN buses application

6 /

Auxiliary equipment

classrooms

Furniture, spotlights, multimedia blackboard, cupboards, etc.

workshops

Working benches, engines support, weldins equipment, several tools.

electromechanics

Auxiliary mechanic equipment, frame, steering alignment system, balancing machines, dismantle tyres, etc.

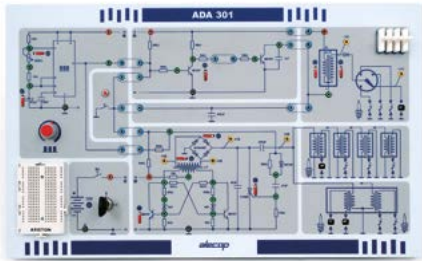

ADA 301: electronics application



ADA 303: sensors application

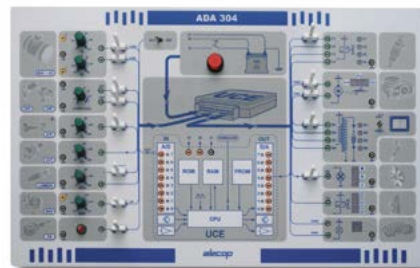

ADA 304: electronic control unit application



ADA 305: actuators application



bodywork

Painting and drying cabins.
Preparation areas, mounting support, meters, several tools, cleaning cabins, protection equipment.

laboratory

Diagnostic instruments, tests bank, fumes extractor, etc.

ADA 300

Application of electricity for automotive

Equipment to study basic automotive electricity.

8 /

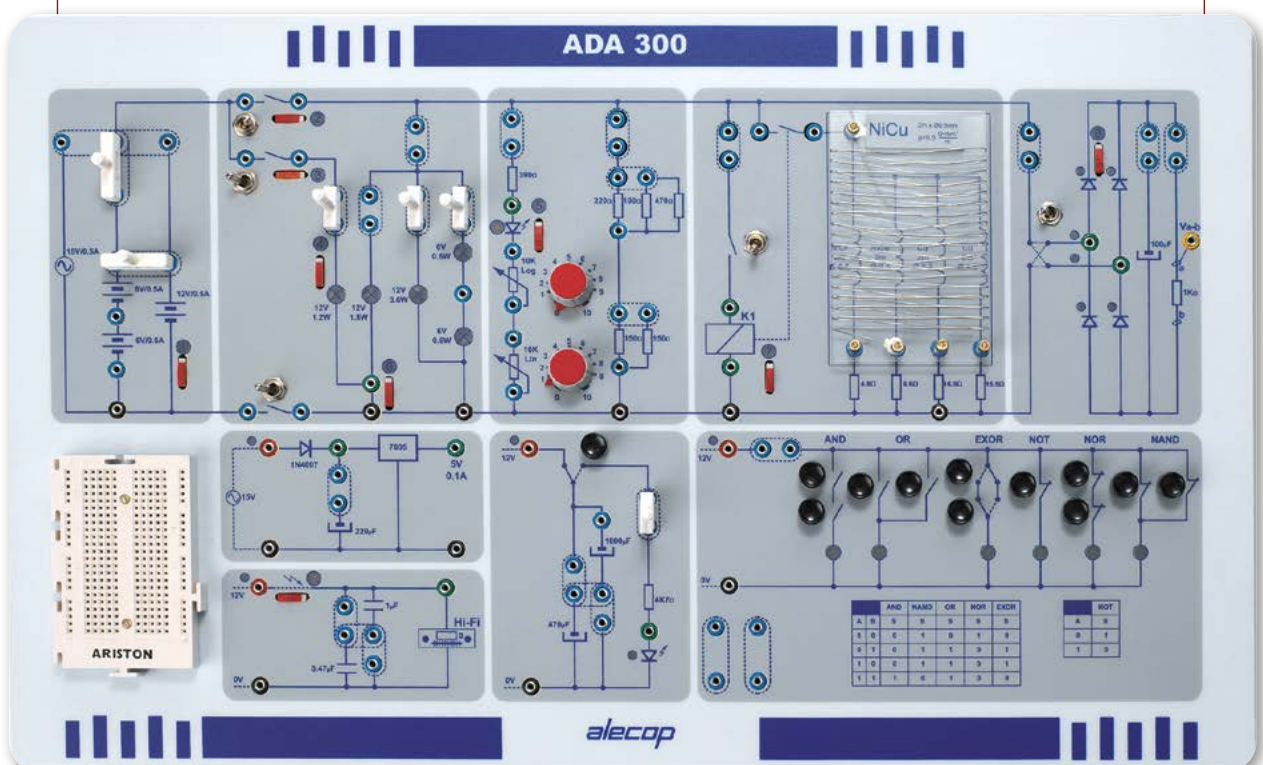

Ref.: 9EQ300AA6C - 230 V

Ref.: 9EQ300AA3C - 115 V

The purpose of this equipment is to familiarise students, in a flexible way, with basic electricity in general and, more specifically, its application in cars. The application can be used to analyse and check different basic electric circuits as well as their components without wasting any time on assembly and dismantling. The configuration of the circuit to be analysed is carried out quickly by means of connection bridges. The equipment enables also the generation of faults in several of the circuit's components. However, if you want to extend some activities, the application has a complementary circuit assembly board. This board enables electric/ electronic elements to be interconnected (resistances, capacitors, diodes, etc.) in a quick and easy way without the need to solder the components, making it possible to reuse the components for several different assemblies.

Technical specifications

- Incorporates the following components/circuits:
 - Power circuit: Alternating current (AC) and direct current (DC).
 - Circuit with lamps: Parallel, series, mixed, lamps with different powers.
 - Circuit with resistances: Parallel, series, mixed, linear and logarithmic potentiometer.
 - Circuit with relay.
 - Circuit with different conductor materials: copper, nichrome and constantan.
 - Full wave/half wave rectifier circuit.
 - Circuits with capacitors: filter, power store.
 - Circuit with logic gates.
- Test points to take measurements on the different circuits.
- Accessibility to all components for analysis under voltage or without voltage.
- Possibility of generating disfunctions in components of the equipment.
- Possibility of doing different electric/electronic assemblies on a proto-board.
- Measurements: 446 x 270 x 100 mm.



9 /

Skills to be developed

- Using equipment to measure electric/electronic components and circuits and interpret the data obtained with the multimeter and the oscilloscope.
- Checking electric/electronic components not undervoltage and under voltage.
- Analysing basic electric/electronic circuits and linking them to car components.
- Assembling basic electric/electronic circuits.
- Running diagnostics and repairing simple faults in car electric/electronic systems.

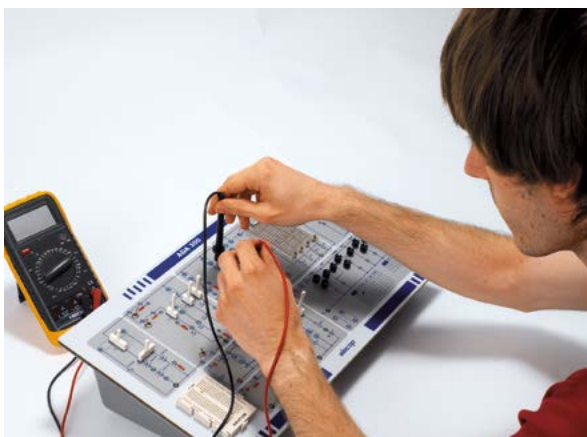

Equipment composition

- ADA300 panel.
- User's manual.
- Manual of practical activities.
- Wires with different conductor materials.
- Electric/electronic components to assemble complementary circuits.
- Accessories store.

Contents to be studied

- AC/ DC power supply.
- Batteries: Characteristic. Association of batteries in series and in parallel.
- Lamps. Identification. Association of lamps.
- Ohm's law: voltage, current, resistance.
- Association of resistances in series and in parallel.
- Characteristics of linear and logarithmic potentiometers.
- Electric power.
- Conductor materials: Copper, nichrome and constantan.
- Study of capacitors in DC: Filter, power store.
- Binary logic: AND, OR, EXOR, NOT, NOR and NAND.
- Full wave/Half wave rectification, filtering with capacitor.
- Components: Resistances, capacitors, diodes, leds, potentiometers, lamps, relays.

ADA 301

Application of electronics for automotive

Equipment to study the electronics applied in automobiles.

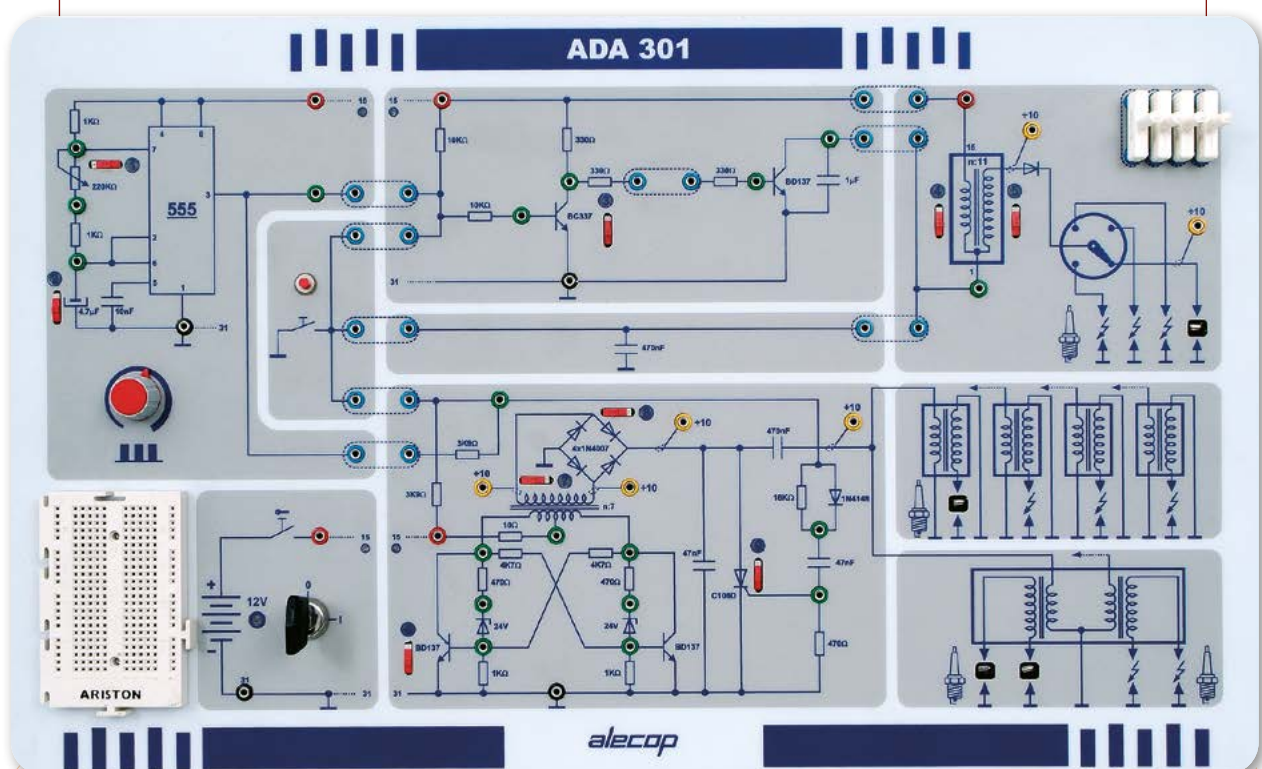

10 /

Ref.: 9EQ301AA6C - 230 V

Ref.: 9EQ301AA3C - 115 V

The ignition circuit has been taken as the common theme throughout the process of teaching applied electronics in the automobile. This circuit has undergone significant improvements throughout history until reaching the current solutions which are largely derived from the use of electronics. This has been one of the reasons why we have decided to base part of the study of electronics for the car industry on this real automobile application.

The application has different electronic circuits which can be combined together to assemble the different systems used in designing ignition circuits:

- Ignition spark generation using a switch.
- Ignition spark generation using a transistor circuit.
- Ignition spark generation using a condenser discharge system.

Technical specifications

- Incorporates the electronic blocks which are necessary to analyse the following circuits:
 - Power pack.
 - Circuit to generate sparks using a switch.
 - Multi-vibrator circuit or square signal generator.
 - Circuit to generate sparks using a transistor.
 - Circuit to generate sparks using a condenser discharge system.
 - Power circuit for a DC motor.
 - Circuit to vary the speed of a DC motor.
 - Circuit to vary the luminosity in the lights.
- Test points to take measurements on the different circuits.
- Accessibility to all the electronic components for analysis under voltage or without voltage.
- Possibility of generating disfunctions in different components of the equipment.
- Possibility of doing different electronic assemblies on a proto-board.
- Measurements: 446 x 270 x 100 mm.



11 /

Skills to be developed

- Using equipment to measure electronic components and circuits and interpret the data obtained with the multimeter and the oscilloscope.
- Checking electronic components not under voltage and under voltage.
- Analysing general electronic circuits and linking them to car components.
- Assembling basic electronic circuits.
- Running diagnostics and repairing simple faults in car electronic systems.

Equipment composition

- ADA301 Panel.
- User's manual.
- Manual of practical activities.
- 12V dc motor.
- 12V/6W light.
- Electronic components to assemble complementary circuits.
- Accessory store.

Contents to be studied

- Study and checking the operation of different electronic components: Diode, transistor, zener diode, thyristor.
- Basic study of the different ignition systems used in cars.
- Circuit which inverts the polarity of the current in the transistor ignition circuit.
- Current amplifying circuit.
- Integrated circuit: NE555 Multi-vibrator.
- Rectifier circuit.
- Generation of variable time signals.
- Generation of high voltages starting from low voltage.
- Condenser discharge circuit on coil primer.
- Voltage variation applied to a device (engine, lamp, and valve).

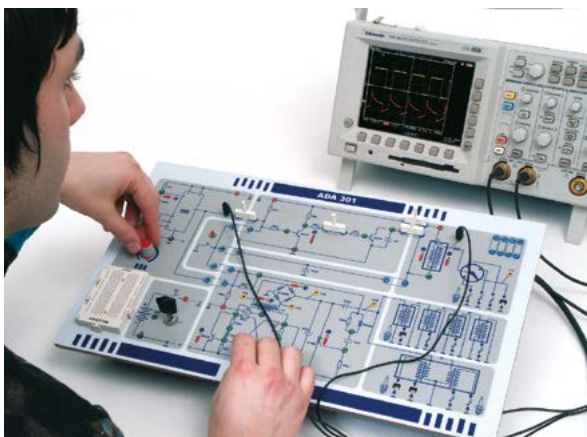

ADA 303

Application of sensors for automotive

Equipment for the study of sensors in a car.

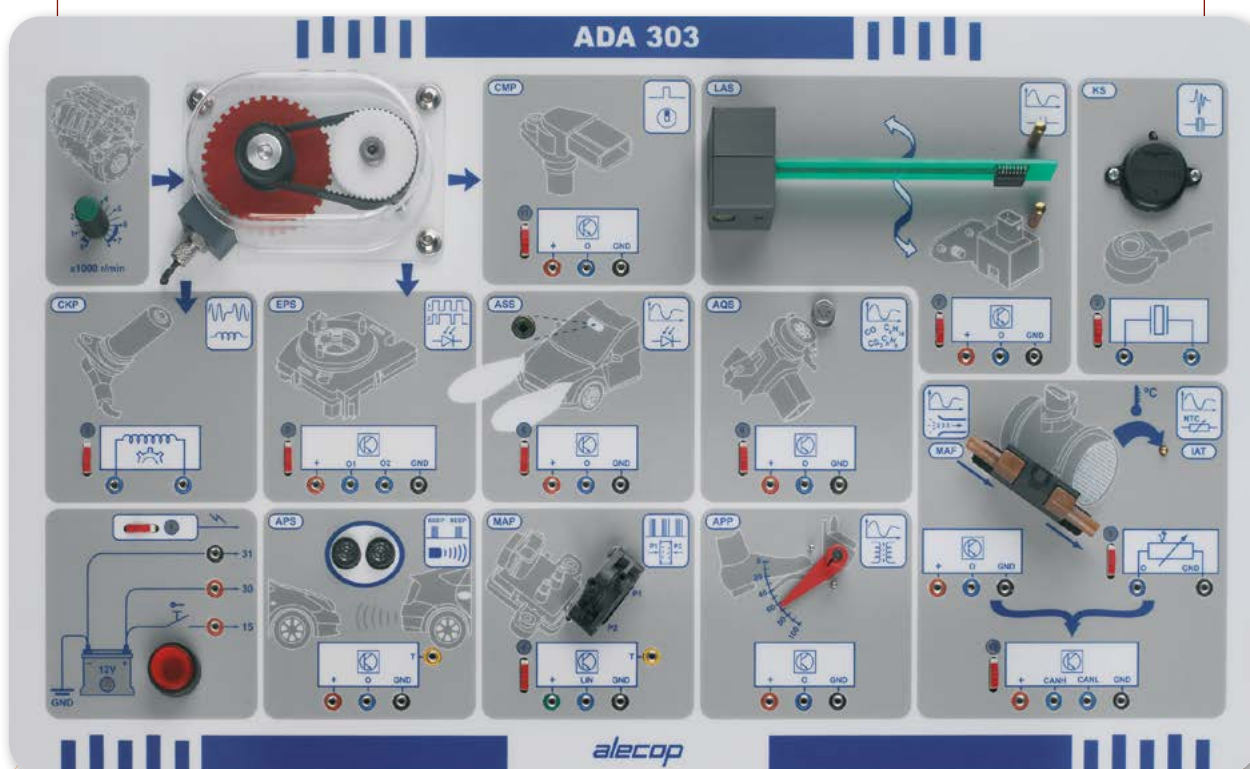

12 /

Ref.: 9EQ303AA6C - 230 V

Ref.: 9EQ303AA3C - 115 V

Equipment conceived to study different sensors, depending on technologies, types of regulation, capturing parameters and means of transmission of information used in the different electrical electronic systems which can be found at present in a vehicle. Thanks to these sensors the electronic systems receive information of the physical and or chemical magnitudes necessary through the ECU in order to make the calculations required to start the different actuators working. The actuators will be in charge of producing the physical variations which make the different electromechanical components of the vehicle work. The equipment has 12 sensors, similar to those actually used in the car (CKP-CMP-MAF-MAP etc.) through which and thanks to the combination of different technologies used in their construction a high number vehicle sensors can be studied. Some of the signal reception elements can be connected to the UCE ADA304 application, and along with the ADA305 actuator they make the equipment form a complete electronic control system.

Technical specifications

- Autonomous equipment for the study of sensors in a car.
- The equipment includes sensors using different types of technology:
 - Crankshaft position sensor: inductive.
 - Camshaft sensor: Hall.
 - Steering column sensor (position, speed): Optical.
 - Light sensor: Optical.
 - Parking distance sensor: Ultrasound.
 - MAP collector absolute pressure system: Piezoresistive.
 - Lateral acceleration sensor for electronic stability control: Capacitive.
 - Air quality sensor: MOS (Metal Oxide Semiconductor).
 - Accelerator pedal position sensor APP: inductive.
 - KS Knock sensors: Piezoelectric.
 - Air mass sensor MAF: Hot wire.
 - IAT air temperature admission sensor: NTC Resistive.
- The communication of the sensors with the outside is carried out by different means:
 - Digital output.
 - Analogue Output.
 - Communication by CAN bus.
 - Communication by LIN bus.
- Each sensor has information printed on it about:
 - The technology used.
 - Type of output generated.
 - Physical shape of the sensor in the vehicle.
- Testing points protected against possible incorrect manipulations, for carrying out measurements at the different points of the circuit.
- Possibility of generating faulty situations in the signal sent by the sensors to the ECU, enabling the analysis of malfunction in the system.
- Possibility of connecting various sensors to the ECU control unit panel ADA304.
- Measurements: 446 x270 x100 mm.

Training to be carried out

- Analysis of the working of the different sensors and their association in the different automobile systems.
- Testing electrical/electronic signals without voltage and under voltage.
- Diagnosis of faults in the sensors: Lack of supply, broken sensor, short circuit to mass or to positive of the sensor, failure in the bus of communication of the sensor (CAN-LIN) etc.
- Instrumentation handling: Oscilloscope, Polymeter.

Equipment composition

- ADA303 Panel.
- User manual.
- Practise activity manual.
- Accessories: Syringe and plastic tubes.
- Accessory store.

13 /

Contents to be studied

- Technologies used in sensor design.
- Types and characteristics of sensors.
- Types outputs (analogue, digital, CAN bus, LIN bus).



ADA 304

ECU electronic control unit

Equipment for the study of electronic control systems in a car.

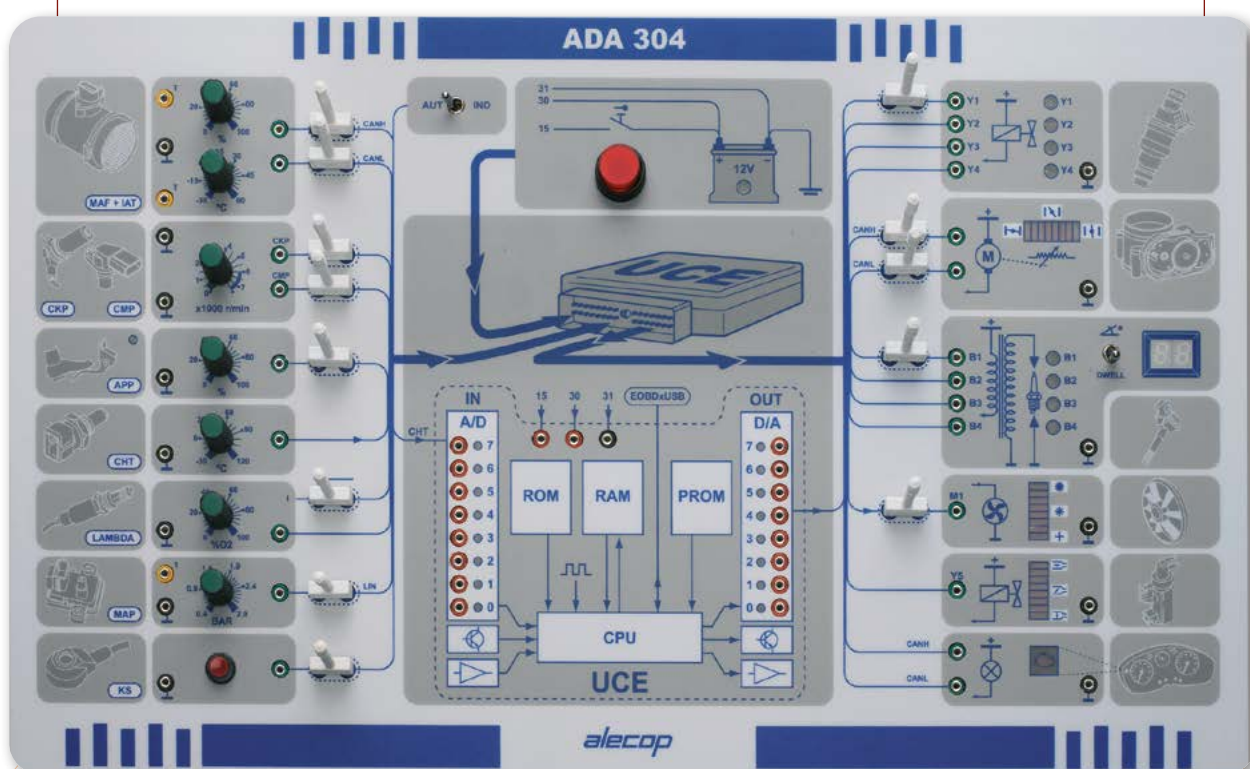

Ref.: 9EQ304AA6C - 230 V

Ref.: 9EQ304AA3C - 115 V

Equipment to study how the electronic control unit (ECU) of a petrol engine works with a multipoint sequential injection system and static ignition. The equipment enables, by means of a series of potentiometers, different operation conditions to be simulated (amount and air mass, temperature, rpm, cooling temperature etc.) which the ECU, depending on the programming, uses to carry out the necessary calculations and make the different system actuators work (injectors, coils, air flow valve, electrofan, etc). Input and output signals can be adjusted independently. Nevertheless, to avoid malfunctions (unlikely) on the injected system, an AUT mode has been implemented where the sensor signals evolves depending on the programmed algorithm thus allowing the student to quickly begin to understand how the injection system works. Similarly, it incorporates the auto-diagnosis system which alongside the DD-Car software allows the student to become familiar with auto-diagnosis techniques.

Technical specifications

- Stand-alone equipment that incorporates the simulation of the following sensors and actuators:
 - **SENSORS:** Air mass sensor, air admission temperature, crankshaft position, camshaft position, accelerator pedal position, coolant temperature, wide band Lambda sensor, absolute pressure sensor and vibration sensor.
 - **ACTUATORS:** Gas injectors, gas valves, spark plugs, Turbo electrovalve and MAL (Malfunction Indicator Lamp).
- Sensor and actuator communication with the ECU by different types of signal; analogue, digital, multiplexing buses CAN and LIN.
- Testing points protected against possible incorrect manipulations, for carrying out measurements at the different points of the circuit.
- Possibility of generating malfunctions in the signal sent by the sensors to the ECU.
- Automatic or individual operation of the sensors (AUT/IND).
- Reprogramming function (Flash) of the ECU as a Turbo motor or Atmospheric.
- Auto-diagnosis function implemented in the ECU.
- Possibility of disconnecting the sensors/actuators simulated in the panel and of connecting the real sensors/ actuators of the ADA303 and ADA305 applications.
- Measurements: 446 x270 x100 mm.

Equipment composition

- ADA304 Panel.
- User manual.
- Practise activity manual.
- DD-Car auto-diagnosis software.
- Accessory Store.



DD-Car

AUTO-DIAGNOSIS SOFTWARE

DD-Car is a Diagnosis Teaching Tool prepared to work with the ADA304. Working with DD-Car will allow the student to become familiar with the operation of auto-diagnosis consoles on the market allowing their adaptation to any of them to be quicker and easier, in addition testing can be carried out without the risk entailed on working directly on the systems of the vehicles. The following functions can be made:

- Reading and deleting the breakdown code.
- Reading of values and analysis in real time of the operation of the system.
- Activation of the actuators.
- ECU Programming (flash).
- Carrying out basic adjustments in the system.

Training to be carried out

- Analysis of how the electronic injection control unit works on an ECU- Motor.
- Analysis of the ECU input signals.
- Analysis of the ECU output signals.
- Testing electrical/electronic signals with without voltage and under voltage.
- Handling of auto-diagnosis tools: DD-Car.
- Fault Diagnosis: Broken sensor, failure in the communication bus (CAN-LIN), etc.
- Testing of sensors and actuators using an autodiagnosis tool.
- Instrumentation handling: Oscilloscope, Polymeter.



15 /

Contents to be studied

- CU Sensor inputs: types, characteristics etc.
- Actuator outputs from the ECU: types, characteristics etc.
- Internal architecture of an electronic control unit.
- Working of an electronic injection control unit, injection control algorithms.
- Injection time and ignition time (ignition angle and DWELL angle).
- Types and characteristics of sensor/actuator signals: Analogue, digital, multiplexing buses (CAN and LIN).
- Auto-diagnosis in electronic injection systems, failure EOBD codes.
- Reprogramming (Flash) of the electronic control unit.
- Digital /Analogue and Analogue/ Digital conversion.

ADA 305

Actuator applications for the automotive industry

Equipment for the study of actuators in a car.



16 /

Ref.: 9EQ305AA6C - 230 V

Ref.: 9EQ305AA3C - 115 V

Equipment conceived to study different actuators, depending on technologies, types of regulation and means of control used in the different systems which can be found at present in a vehicle. These actuators are controlled from the electronic control unit ECU based on control algorithms programmed on the unit, which are responsible for making the system respond to the variation required for the behaviour of the vehicle. The equipment has 10 actuators, similar to the ones in use at present in a car (spark plug, injector, step motor, canister valve, etc.), through which, and thanks to the combination of different technologies they use and of the different means of control, they allow a high number of vehicle actuators to be studied. Some of the equipment actuators can be controlled from application UCE ADA304, and can together with the ADA303 sensor equipment form a complete control system.

Technical specifications

- Autonomous equipment for the study of actuators in a car.
- The actuators included in the equipment are:
 - Ignition coil with incorporated spark.
 - Electromagnetic injector.
 - DC Motor: Open loop speed control and closed loop control position potentiometre on the shaft.
 - Cooling fan: Analogue or series resistance speed control.
 - Electrovalve: All/Nothing Control (ON/OFF) and linear control by means of Pulse Width Modulation (PWM).
 - Electromagnet: ON/OFF Control.
 - Windscreen washer motor pump: Motor pump control in both directions.
 - Step Motor: Two working speeds.
 - Actuators related with lighting: Position-brake light, emergency warning lights, lights on warning.
 - Acoustic actuator, piezoelectric buzzer: Actuation of the same with two different tones.
- The control technologies implemented are:
 - Digital control.
 - Analogue Control.
 - Control by CAN bus.
 - Control by pulse width modulation PWM.
- Testing points protected against possible incorrect manipulations, for carrying out measurements at the different points of the circuit.
- Possibility of controlling various actuators from the control unit ECU-ADA304.
- Measurements: 446 x270 x100 mm.

Equipment composition

- ADA305 Panel.
- User manual.
- Practise activity manual.
- Accessory store.

Skills to be developed

- Analysis of how the different actuators work.
- Testing electrical/electronic signals with without voltage and under voltage.
- Diagnosis of faults in the actuators: Lack of supply, actuator broken, short circuit to mass or to actuation positive, failure in the communication bus of the actuator (CAN-LIN).
- Instrumentation handling: Oscilloscope, Polymeter.

17 /

Contents to be studied

- Technologies used in the actuator design.
- Types and characteristics of actuators.
- Types actuator control systems (analogue, digital, CAN bus, LIN bus).

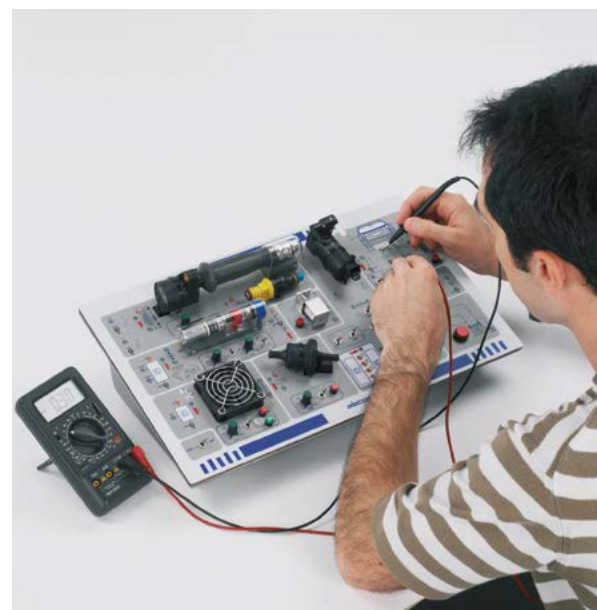

ADA Engine

With Auto-diagnosis

Auto-diagnosis in electronic injection systems EOBD. Study of the sensors, power units and actuators applied to the car.

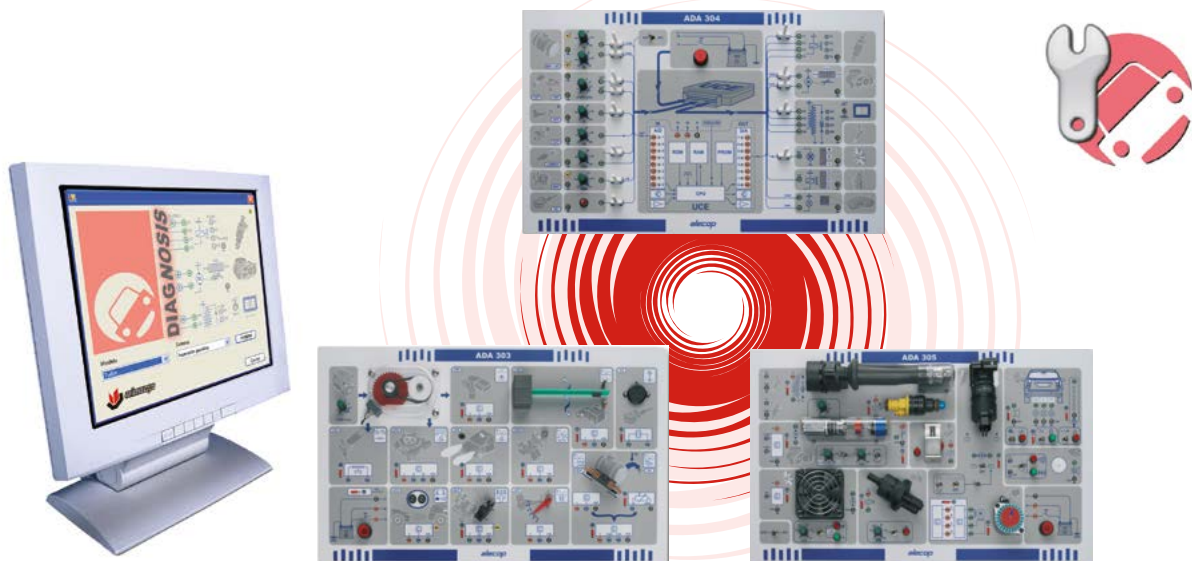

18 /

By means of connecting the ADA303 application sensors and the ADA305 actuators to the UCE ADA304, the injection system of a basic atmospheric or turbo engine can be simulated. Then, in this engine we can observe, through the auto-diagnosis DD-Car, how the engine parameters process is changing in a real time. One of the main features of this set of equipments is that it can be adapted to all the formative requirements and needs, as required. On one hand, the individual acquisition of each equipment allows us to work and study each group of components on an individual basis; ADA 303 study of the sensors, ADA 304 study of the control unities with auto-diagnosis and ADA 305 study of the car actuators. Developing in each case the analysis abilities, checking and diagnosis. The acquisition of the three equipments, in which all the components are accessible and very easy to recognize (sensors, UCE, actuators), and where the student himself will have to assemble and operating the fuel injection system in an interconnected way, carrying out manually the electrical-electronical association of all the components required (sensors, UCE, actuators). So that the student is a very active element in the learning process, aware at every moment of the steps he has to carry out to make the system operate correctly, so that the student himself checks very rapidly, directly and visually the work he has done. A very important point to underline is that the student will be able to carry out a very fast and real introduction to the auto-diagnosis through the DD-CAR software, seeing in real time the variation of the parameters of the sensors, the reading and deleting of the breakdown code, the activating, programming and basic adjustments, all of which controlled by the current EOBD norm. The work with DD-CAR will allow that the student get accustomed with the running of auto-diagnosis consoles of the market, so that he can adapt to any one of them very rapidly after having worked with the above-mentioned software.

Technical specifications

- Set of equipments that allows working with real or simulated sensors applied to the current car, making possible a rapidly and visually observation of the running as a whole of many electrical-electronical components of a generic injection system (fuel or current diesel).
- Sensor and actuator communication with the ECU by different types of signal; analogue, digital, multiplexing buses CAN and LIN.
- Testing points protected against possible incorrect manipulations, for carrying out measurements at the different points of the circuit.
- Possibility of generating malfunctions in the signal sent by the sensors to the ECU.
- Reprogramming function (Flash) of the ECU as a Turbo motor or Atmospheric.
- Auto-diagnosis function implemented in the ECU.
- Possibility of disconnecting the sensors/actuators simulated in the panel and of connecting the real sensors/ actuators of the ADA303 and ADA305 applications.
- Measurements: 446 x 270 x 100 mm.

Equipment composition

- Sensor application, ADA303.
- ECU application, ADA304.
- Actuator application, ADA305.
- User manual.
- Practise activity manual.

Contents to be studied

- Technologies used in the sensor design.
- Types and characteristics of sensors.
- ECU Sensor inputs: types, characteristics, etc.
- Technologies used in the actuator design.
- Types and characteristics of actuators.
- Actuator outputs from the ECU: types, characteristics, etc.
- Internal architecture of an electronic control unit.
- Working of an electronic injection control unit, injection control algorithms.
- Injection time and ignition time (ignition angle and DWELL angle).
- Types and characteristics of sensor/actuator signals: Analogue, digital, multiplexing buses (CAN and LIN).
- Auto-diagnosis in electronic injection systems, failure EOBD codes.
- Reprogramming (Flash) of the electronic control unit.
- Digital /Analogue and Analogue/ Digital conversion.

AUTO-DIAGNOSIS software

DD-Car is a Diagnosis Teaching Tool prepared to work with the ADA304. Working with DD-Car will allow the student to become familiar with the operation of auto-diagnosis consoles on the market allowing their adaptation to any of them to be quicker and easier, in addition testing can be carried out without the risk entailed on working directly on the systems of the vehicles.

The following functions can be made:

- Reading and deleting the breakdown code.
- Reading of values and analysis in real time of the operation of the system.
- Activation of the actuators.
- ECU Programming (flash).
- Carrying out basic adjustments in the system.



19 /

Skills to be developed

- Analysis of the working of the different sensors and their association in the different automobile systems.
- Testing electrical/electronic signals without voltage and under voltage.
- Diagnosis of faults in the sensors: Lack of supply, broken sensor, short circuit to mass or to positive of the sensor, failure in the bus of communication of the sensor (CAN/LIN) etc.
- Analysis of how the electronic injection control unit works on an ECU-Motor.
- Analysis of the ECU input signals.
- Handling of auto-diagnosis tools: DD-Car.
- Testing of sensors and actuators using an auto-diagnosis tool.
- Instrumentation handling: Oscilloscope, Polymeter.



ADA 306

Automotive multiplexed CAN-LIN buses

Equipment for conceptual study of the data networks and multiplexing in the car.

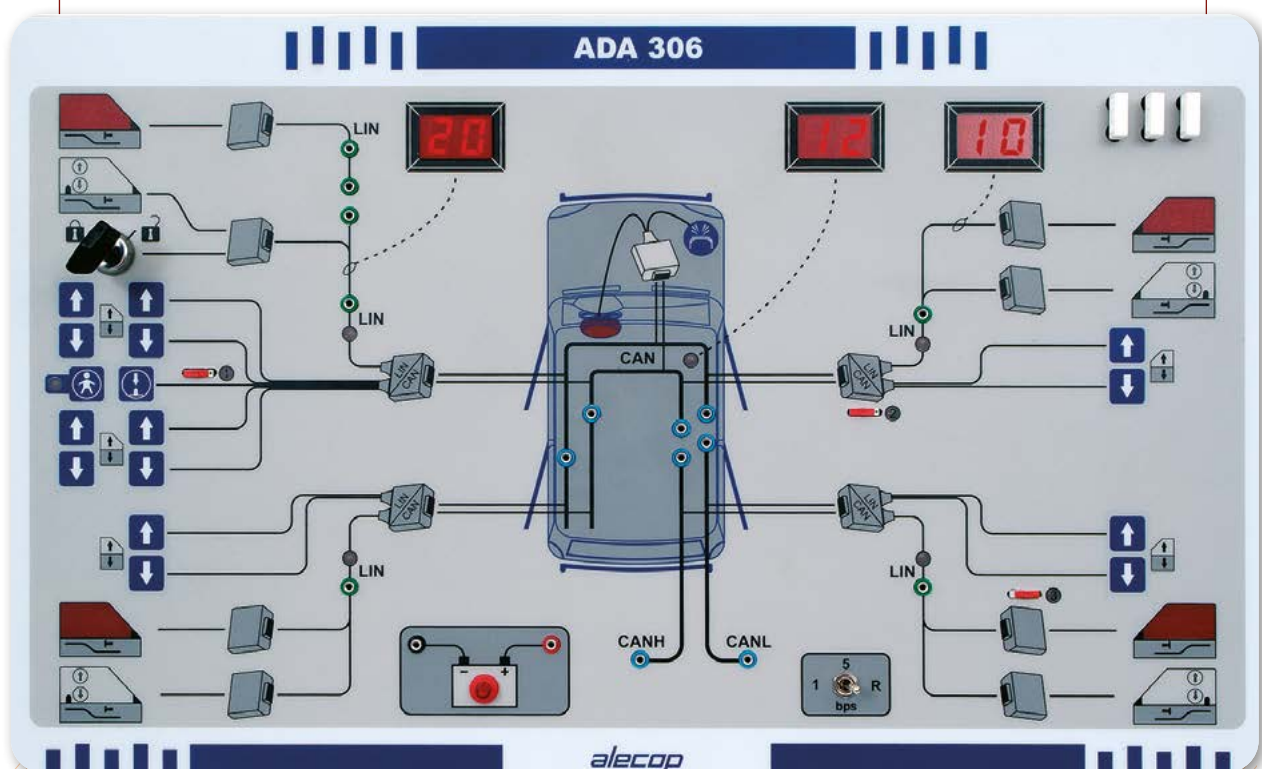

20 /

Ref.: 9EQ306AA6C - 230 V

Ref.: 9EQ306AA3C - 115 V

The objective of this equipment is to familiarise the student with data and multiplex networks. The information is transmitted by means of two buses: CAN (Controller Area Network, ISO 11898-3 or ISO 11519-2 specification) and LIN (Local Interconnect Network).

The equipment allows the operation of the two buses implemented in real mode and in slow mode to be analysed. This latter mode allows analysis how the series data transmission, employed in all multiplexed buses, operates in a simple and very didactic way. In the real mode the two buses operate at real speed (125 Kbits/sec for the CAN and 19.200 bits/sec for the LIN) whilst the slow mode can operate at 1 bits/sec or at 5 bits/sec. while makes it easy to analyse the data which has been sent.



Technical specifications

- Implementation of multiplexed comfort bus with CAN ISO 11898-3 line which is tolerant to faults at 125 Kbits/sec.
- Implementation of switch and electric window control in the vehicle doors with LIN bus at 19.200 bits/sec.
- Test points in the different lines of the buses.
- Possibility of generating dysfunctions in the different buses:
 - Short circuits to battery and to earth.
 - Short circuits between the lines.
 - Cuts in the lines.
 - Simulation of faults in the control units I.
- Real or slow operation selection switch. It allows analysis of operation with an oscilloscope (real operation) or using a multimeter (slow operation).
- In slow mode, display of the different frames which are circulating in the buses on alphanumeric displays in hexadecimal notation.
- Possibility of CAN communication using optical fibre. It substitutes the conventional wiring with optical fibre in the CANH or CANL lines.
- Measurements: 446 x 270 x 100 mm.

Equipment composition

- ADA306 Panel.
- User's manual.
- Manual of practical activities.
- ACCFI306ZX: accessory to transmit data by optical fibre.
- Accessories store.

Skills to be developed

- Analysis of multiplexed systems.
- Handling instrumentation for checking and diagnosis.
- Running diagnostics and repairing faults in multiplexed systems.

Contents to be studied

- Binary logic.
- Numerical systems (Binary, hexadecimal).
- Transmission of information in series.
- Layouts of data networks (Multi-Master, Master-Slave).
- CAN Bus (Transmission of differential data, voltage levels, frames, fault tolerance, etc.).
- LIN Bus (Transmission of differential data, voltage levels, LIN frames, etc.).
- Transmission of data by optical fibre.

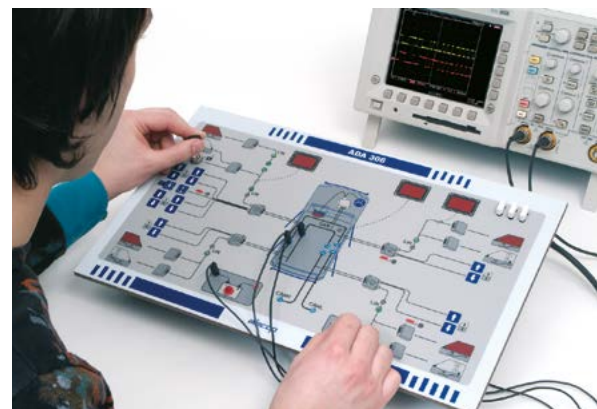

ADA 307

Hybrid vehicle application

Conceptual studies of combined cycle hybrid vehicles.



22 /

Ref.: 9EQ307AAZC

The goal of this equipment is to get students to know hybrid vehicle technology. The application uses the most efficient system on the market: the plug-in hybrid electric vehicle (PHEV).

The application consists of a panel showing all the parts of a hybrid vehicle and a virtual instrument panel with advanced functions for data generation, acquisition, and analysis. This system is used to:

- Make conceptual studies in combined cycle PHEVs simulating the operation of a real vehicle on different journeys and contexts.
- Assess high-voltage electricity flows.
- Analyse the power combination of an internal combustion engine and an electric motor/generator.

It includes an application developed with MATLAB/Simulink, the user manual, and practical exercises.

Interactive panel

The interactive panel has the same devices as a vehicle: start switch, accelerator, brakes, speed selector, A/C switch, and off-board battery charge button (plug-in). It reproduces the different stages in an engine operation cycle (electric motor, internal combustion engine) as well as the battery pack status (charged, depleted, generator). Two measuring positions, V1/V2, to check the parameters selected with the software:

- Battery pack charge level.
- Battery voltage.
- Battery charging current.
- Electric motor work voltage.
- Vehicle speed.

Virtual model

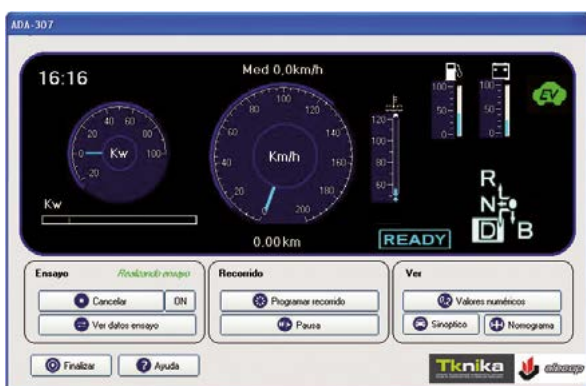

The hardware trainer is a driving simulator (gear, speed, battery charge, fuel gauge). All the actions performed on the panel are represented in the software instrument panel.

The ADA307 software provides information on vehicle performance in figures, graphics, and gauges. The user can choose to view the numerical data screen, the nomogram screen, or the synoptic chart screen.

Synoptic graphic



Data acquisition

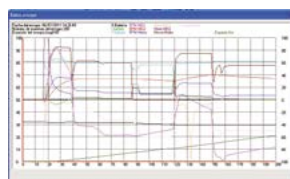

Nomogram

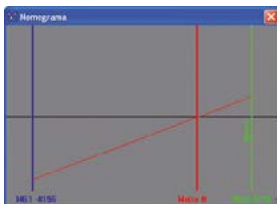

The effect of various situations on hybrid vehicle performance can be assessed by programming journeys and carrying out tests. The data can be exported to Excel.

Programming journeys



The virtual model shows all operating stages:

- Electric motor.
- Internal combustion engine.
- Electric motor + internal combustion engine and overlapping mode.
- Energy restoration and battery charging.

23 /

Modelling with MATLAB Simulink® simulHyb

It is delivered as executable software to be used with no need of a MATLAB licence, including sources.

SimulHyb offers:

- Vehicle operating simulation (considering weight, fuel level, vehicle power, etc.)
- Energy distribution simulation:
 - in acceleration mode (consumption).
 - in braking mode (recharge).

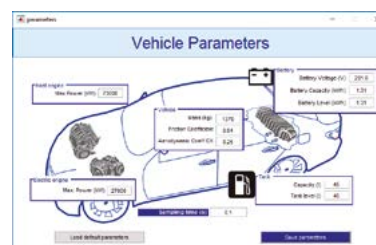

MATLAB and Simulink® sources included

ADA 308

Electric vehicle application

Conceptual study of electric vehicles.



24 /

Ref.: 9EQ308AAZC

The goal of this equipment is to get students to know electric vehicle technology and main parts currently used in electric vehicles as well as the behaviour depending on the route and type of driving. This system is used to:

- Make conceptual studies in electric vehicles simulating the operation of a real vehicle on different journeys and contexts, defining the duration and speed by sections.
- Carry out tests by capturing data on the main parameters that affect an electric vehicle during its operation.
- View the computer graphic representation of the battery values, performance, and variation of various vehicle elements.
- Analyse the high voltage current flows through a synoptic diagram.
- Analyse the force combination between electric motor / generators, measure and record the actual values (rpm, torque, HV battery current, vehicle speed etc.).

Four different models of electric vehicles can be selected with their real parameters: motorcycle, quadricycle, car and van based on the commercial models LEM, Renault Twizy, Nissan Leaf and Mercedes Vito respectively. Their parameters can be modified.

The application is interactive with the software through the different joystick components (accelerator, brake, automatic gear) and allows that different measurements can be made.



Interactive panel

It integrates the commands of the vehicle:

- Start / Stop switch.
- Plug-in battery charging switch.
- Light indicators of the status of the vehicle and the parts that are working.
- Parking mode switch.
- Gear with position indicators.
- Test or measurement points.
- Accelerator with locking control.
- Brake.
- Activation/deactivation of air conditioning switch.

The two test points V1/V2 allow the measurement of the parameters selected from the software:

- Battery charge level.
- Speed in km/h.
- % Accelerator pedal.
- % Brake pedal.
- Engine RPM.
- Slope of the road.
- Battery voltage.
- Battery current.

It includes User's and Practical manuals in digital format.

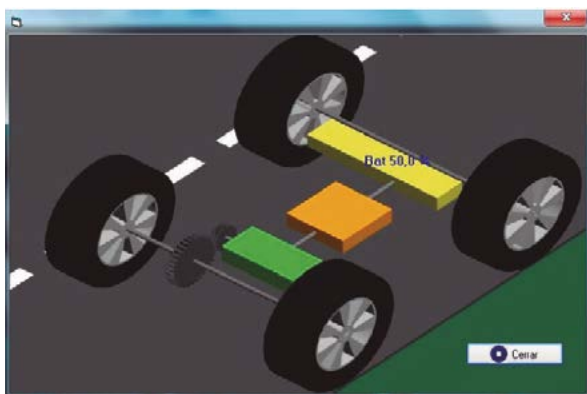

Synoptics

Control and analysis software

It includes different functions:

- Dashboard.
- On-board computer.
- Definition of driven conditions.
- Equipment for the diagnosis of the different parameters.

On the screen you can simulate the operation, supervise the possible measures to be taken, program the routes, visualize and read the operation parameters.

25 /



Dashboard



Parameters analysis



Machine Tool professionals are among the most sought after by companies. The competencies behind the qualifications in this field are complex and range from the interpretation of plans to working in Industry 4.0 environments.

Our classroom proposal is based on the combination of CNC machines, mechanical design software and NC programming Alecop software, generating an efficient and motivating environment for students and tutors.

All this equipment has the following educational aims:

- CNC Programming.
- Operator skills.
- Implementation and maintenance of CNC machines.



WinUnisoft+

WinUnisoft+



VIRTUAL MACHINES

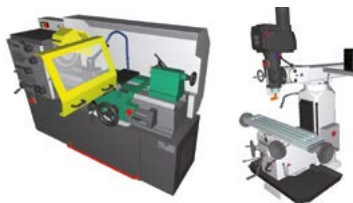

BABYPLAST



Characteristics

- Machines of different sizes and features.
- Control of machines via PC, using multi-panel software (Fanuc, Fagor, Siemens).
- Software for CNC programming and simulation in different programming languages.
- Virtual machines.
- Assembly and mechanical maintenance kits.

As well as our trainers, we distribute all the necessary material and equipment to complete your classroom/workshop.

Integral equipment

- Adjustment
- Bench grinders
- Sharpeners
- Welding drills
- Saws
- Tracing table
- Pneumatics
- CAD
- Utensils and tools
- Safety equipment
- ...

Atenea

CNC machining centre with integrated PC control



A vertical milling machine, controlled by an integrated PC, **ATENEA** goes one step further in bringing our training equipment closer to today's industrial world.

The integrated PC controlling the machine has multi-control software and a touch screen to provide a close-to-reality experience while remaining a safe, informative training solution for students. Optional inclusion of relevant accessories can turn the unit into a full machining centre that can be integrated into a flexible system.



Multi CNC. Programming and display of FAGOR, SIEMENS and FANUC simulators. Includes PC, touch screen and keyboard.

28 /

Technical characteristics

Longitudinal X travel	200 mm
Transversal Y travel	200 mm
Vertical Z travel	200 mm
Measurements of the work table	450 x 180 mm
Maximum spindle-table distance	320 mm
Spindle motor	Three-phase asynchronous 1.5 kW
Spindle taper	ISO 30
Spindle motor rotation speed	50-4,000 rpm
Axes advance motors	200 steps/rev
Maximum advance of axes	2,500 mm/min.
Electronic resolution	0.0025 mm.
Door opening	Automatic
Supply voltage	230 V 50/60 Hz
Dimensions of machine	1,460 x 910 x 1,870 mm
Approximate weight	400 Kg

Axes

- Double-nut, pre-tensioned ground spindles, IT5 quality
- Linear guide rails with ball recirculation.
- 1.8° step motor.

Head

- High precision bearings with 2 rows of angular contact balls.
- Max. torque: 7 Nm at 2,000 rpm.

Guard

- Pneumatically operated.

Electronic handwheel



FEED control



Optional accessories

- 8 position tool changer.
- Parts securing device. (Manual or pneumatic jaws).
- ISO-30 tool holder cones. Collets and mills.
- Cooling system.
- Silent compressor.

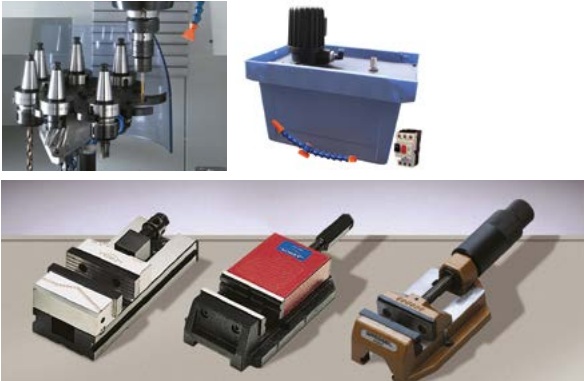

Customizable machine

- Vertical lathe with incorporated safety devices.
- PC, touch screen and keyboard (Wincontrol software installed).
- User's and practical manuals.
- Control software for PC.



WinUnisoft Control SOFTWARE

29 /

This software operates the machine with realistic control emulators (FAGOR, FANUC and SIEMENS).



A license of Winunisoft+ is already included with the machines.

This software allows to simulate and execute the machining of a CNC program, ISO code edited or defined by a CAD/CAM system, analysing possible errors.

The main features of WinUnisoft+ are:

- Control of machine drives.
- Assisted graphic programming for all ISO functions supported by the chosen control emulator.
- Simulation of different tool geometries.
- 3D simulation views of the workpiece, tool and paths.
- Launch program in automatic mode or block to block.
- Collision detection of the tool with the workpiece and the jaw chuck.
- Report generation.

Apart from its performance, the excellent graphic quality of the graphic 3D simulator, makes a fast comprehension possible of the performed machining operations on the workpiece.

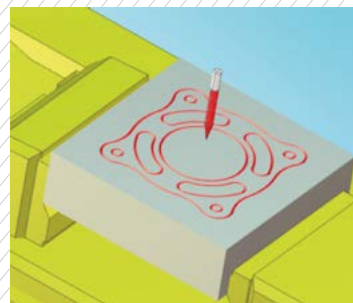

More information in the WinUnisoft+ report.

Hermes

CNC lathe with integrated PC control



Multi CNC. Programming and display of FAGOR, SIEMENS and FANUC emulators. PC, touch-screen and keyboard included

The Hermes lathe with integrated PC and the control program on the machine itself brings the experience of using a PC-controlled industrial machine closer to reality.

Its touch screen and the interactive interface simulation on each ensure the sense of working with the real control, in addition to the advantage of using software designed to form part of the teaching/learning process.

30 /



Technical characteristics

Swing diameter	230 mm
Distance between centres	530 mm
Longitudinal Z travel	275 mm
Transversal X travel	96 mm
Spindle motor	Three-phase asynchronous 1.5 kW
Spindle rotation speed	50 - 4,000 rpm
X,Z axes motors	step 200 s/rev
Quick advance	2,500 mm/min
Tool holder turret	8 pos (12 x 12 mm)
Electronic resolution	0.0025 mm
Door opening	Manual/Automatic
Power supply	230 V 50/60 Hz
Installed power	1.9 kW
Dimensions	1,350 x 600 x 1,540 mm
Approximate weight	300 Kg.

Axes

- Rectified spindles with double nut, prestressed, IT5 quality.
- Linear guide rails with ball recirculation.
- 1.8° step motor.

Head

- High precision bearings with 2 rows of angular contact balls.
- Max. torque.: 7Nm a 2,000 rpm.

Electronic handwheel



FEED control



Optional accessories

- Manual 60 mm tail stock travel, CM2 morse taper.
- Cooling system.
- Pneumatic 110 mm diameter chuck.
- Tool holder turret with VDI quick change system.
- Automatic access door operated by pneumatic cylinder (for use in CFF).
- Tool holders and carbide inserts.
- Winunisoft editing and simulation software.



Standard configuration

- Integral casing with built-in safety devices.
- Manual 125 mm diameter chuck.
- Conventional tool holder turret.
- Set of user and programming manuals.
- Control software for PC.



WinUnisoft Control SOFTWARE

31 /

This software operates the machine with realistic control emulators (FAGOR, FANUC and SIEMENS).



A license of Winunisoft+ is already included with the machines.

This software allows to simulate and execute the machining of a CNC program, ISO code edited or defined by a CAD/CAM system, analysing possible errors.

The main features of WinUnisoft+ are:

- Control of machine drives.
- Assisted graphic programming for all ISO functions supported by the chosen control emulator.
- Simulation of different tool geometries.
- 3D simulation views of the workpiece, tool and paths.
- Launch program in automatic mode or block to block.
- Collision detection of the tool with the workpiece and the jaw chuck.
- Report generation.

Apart from its performance, the excellent graphic quality of the graphic 3D simulator, makes a fast comprehension possible of the performed machining operations on the workpiece.



More information in the WinUnisoft+ part.

WinUnisoft⁺

Programming, simulation and control of machines

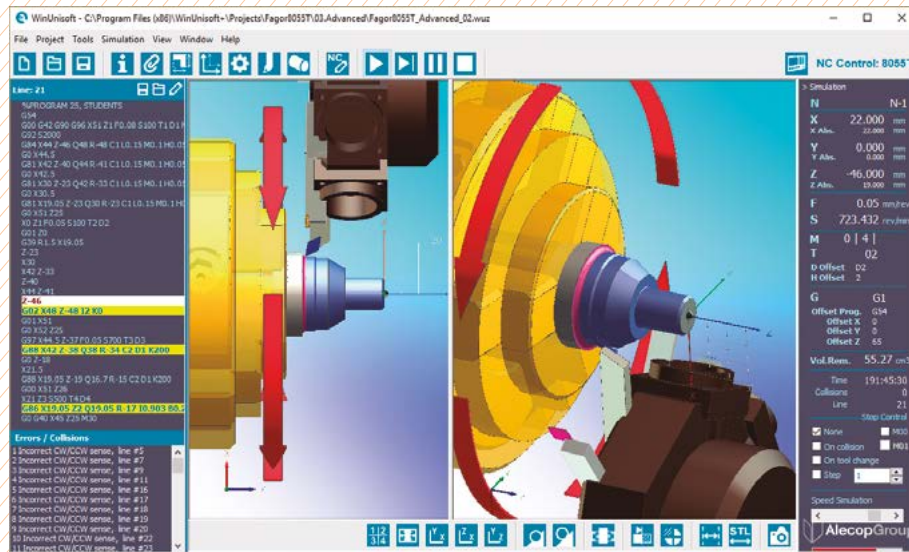

32 /

Learn how to develop your own mechanization projects using the controller of your choice: FAGOR, FANUC and SIEMENS, then complete the job using ALECOPI CNC machines.

This software package, which is the leader in its sector, is intuitive, easy to operate and produces excellent results.

One simulator – Multiple controls. FAGOR-FANUC-SIEMENS

WinUnisoft⁺ has been designed to train in programming of numerical control units and virtually approaches industrial reality with authentic looking control emulation.

It makes it possible to edit and simulate the CNC programs, and furthermore define tool definitions and other necessary parameters for work piece machining on a lathe or milling machine.

The excellent graphic quality of its simulator makes it possible a quick understanding of the different operations performed during machining.

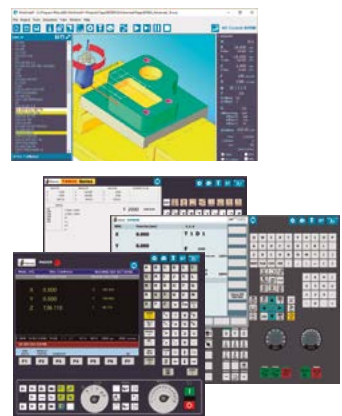

- SIEMENS**
- SINUMERIK 840D-T/M
- FANUC**
- FANUC Series Oi T/M
- FAGOR**
- FAGOR 8050-55 T/M

Optimize your learning-time

ONE software to effectively learn multiple control types

- WinUnisoft⁺ has a very short learning-curve.
- Your students can be practising with different control emulators and programming in multiple languages in a unique and effective environment.
- WinUnisoft⁺ has been conceived to greatly speed-up the learning process.
- Using industrial control simulators for programming means too much time dedicated to learning how to run each one of them.

Integrated into the process

In the process of teaching and learning it is essential to have tools that allow simulation and adaptation of machining programs prior to their actual execution in help avoid problems and reduce the time the machines are used.

Through the use of **WinUnisoft⁺** software, learners can:

- Get to know, understand and master the different programming languages used by the various CNCs.
- Have a first approach to the use of an industrial control thanks to the realistic emulators.
- Make modifications to programs generated by CAD/CAM tools.
- Create their own machining programs.
- Master the basic concepts of machining.

Simulation and control

WinUnisoft⁺ will operate in **Simulation mode** when working with a PC not connected to a machine and in **Control mode** when connected to an ALECOP machine.

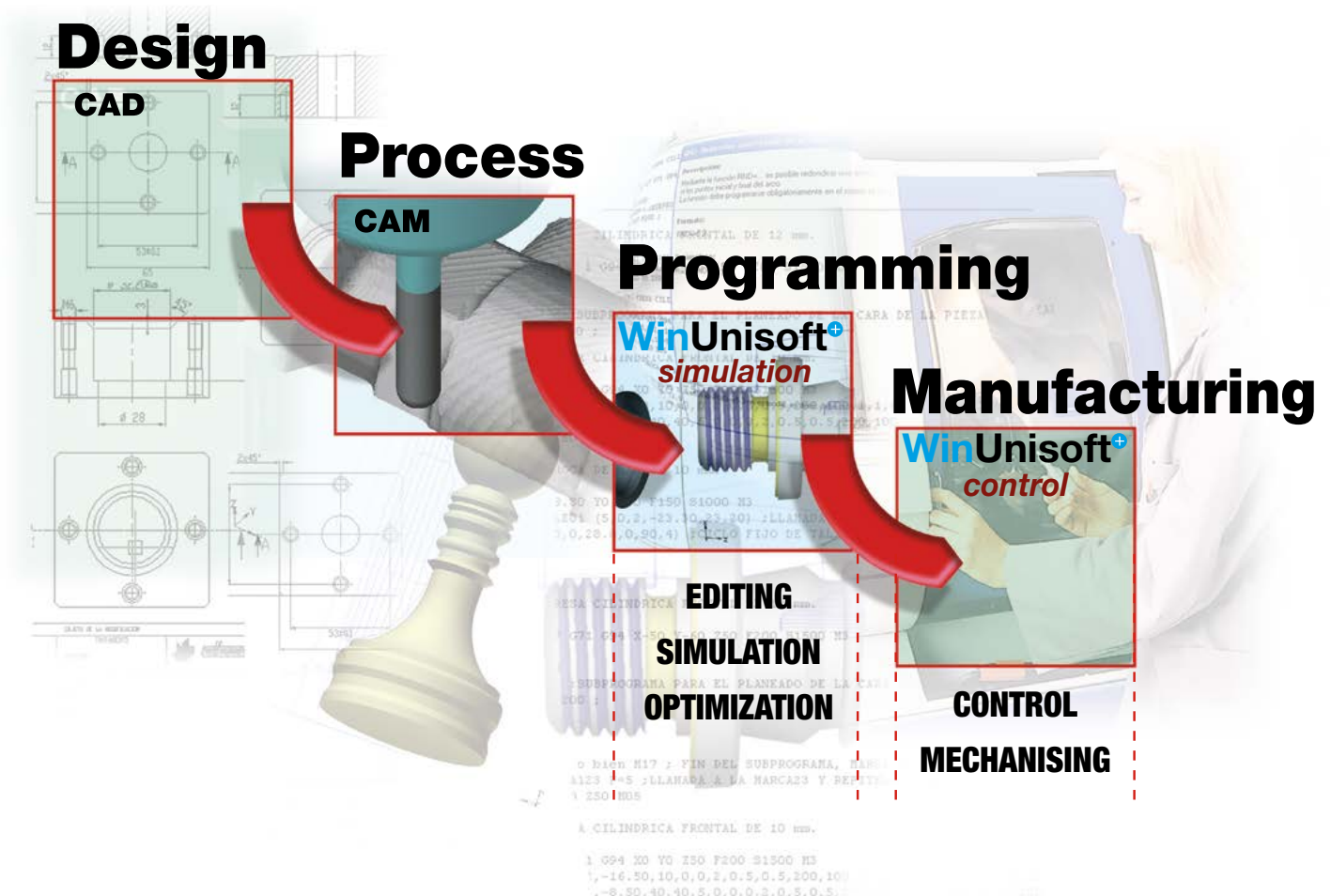

Simulation mode

Project based learning

Unlike industrial simulators, where work only takes place with the machining program, with **WinUnisoft+** the exercises are based on what is known as the "Machining project".

Each exercise is a project and the main goal of the student is to realise the drawing in simulation mode before to mechanizing it.

- The main interface of **WinUnisoft+** is the 3D Simulator.
- The control emulator can be accessed at anytime.
- The job can be completed using the didactic resources each project provides.
- Assistance is provide throughout the programming.
- The finished piece can be measured to check the program and chosen parameters.

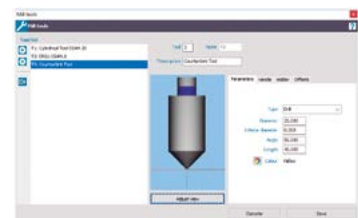
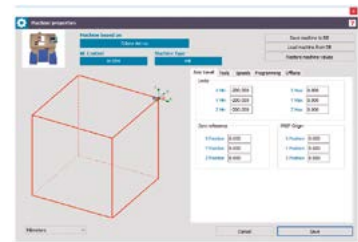

Save time with ready-to-use projects

34 / Includes lathe and milling machine projects with different training levels.

- It is very easy to setup your own projects, but **WinUnisoft+** comes with a wide library of pieces.
- Ready to use.
- Different levels from basic to expert.

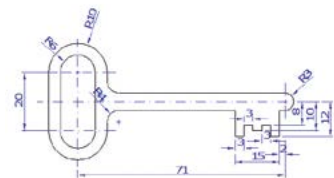

Control mode

Learning by doing

Start controlling the machine using the control of your choice. The main goal is to get the workpiece mechanized.

- The main interface of **WinUnisoft+** the Control Emulator.
- The 3D simulator can be accessed anytime.
- Control of the machine is assisted by the user guides and Help in **WinUnisoft+**.
- Setup of the machine and tool parameters using the control menus or the Assistants in **WinUnisoft+**.
- Programs can be written using assisted programming or just loaded from the network or a pendrive.
- Running the programs will mechanize the workpiece.

The learning becomes meaningful when you are controlled with a challenge.

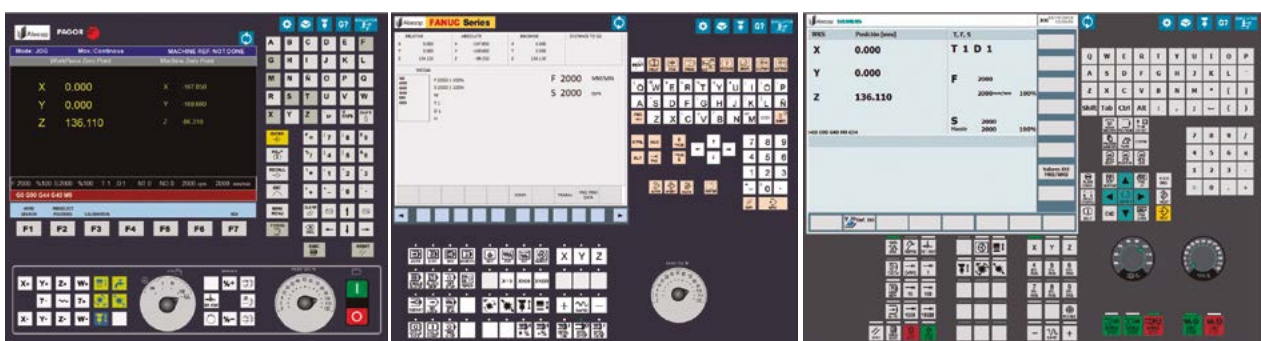

Designed for learning

WinUnisoft⁺ has been specifically designed for use in the teaching and learning process without ignoring the technological contents. The program has been provided with specific features that allow students to acquire knowledge very quickly.

- Graphic help menu for programming all ISO functions.
- Adaptation of the software parameters to any tool machine.
- Definition of different types of workpieces and holding systems.
- Simulation in various 3D views with representation of the tool and workpiece.
- Graphic editor of cutting tools with a wide range of predefined shapes.
- Sectioned display of the work-piece from different angles.
- Collision detection of the tool and the handle with the part and the jaw chuck.
- Inspection and measurement of the shape of the part. Detection of basic shapes (arcs, angles, etc.).
- Report wizard with email.
- Control emulators.

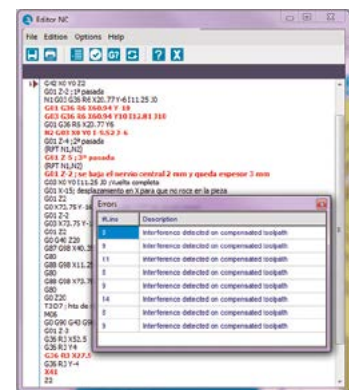

35 /

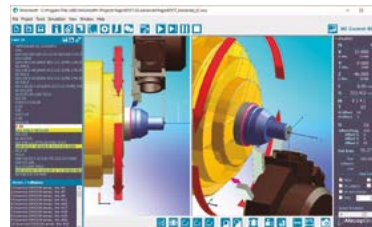

Learning resources

The software includes all the contents the student will need to learn the basics of CNC machine use and numerical control programming.

Our proposal includes:

- Programming guides for all the included languages.
- ALECO PC controlled CNC machines with WinUnisoft⁺ working in control mode.
- ALECO industry NC controlled CNC machines.

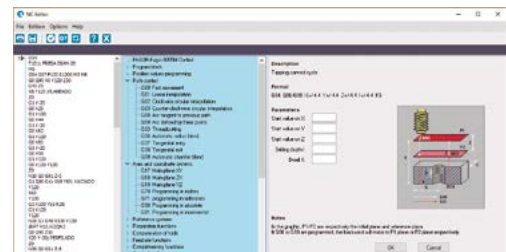
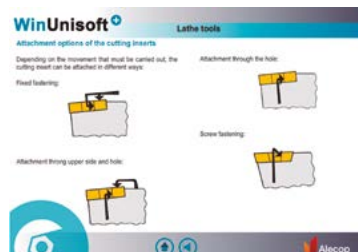

Control emulators

WinUnisoft⁺ has six control emulators that allow the student to learn the real procedures on using CNC machines.

Each emulator has the most characteristic functions to control the machine, and at the same time provides help, if needed, on programming, setting up tools, and setting other mechanizing parameters.

All Alecop's PC controlled machines include a license of WinUnisoft⁺ control.



- Atenea and Hermes had the PC integrated with WinUnisoft⁺ already installed and ready to work. The integral touchscreen gives the system a more industrial feeling.

CNC classroom solution

36 /

Using the machines and the WinUnisoft⁺ software you can configure a CNC Classroom with unlimited programming stations.



Using the features of a local network the teacher can share projects created in the machine with WinUnisoft⁺. The students can use the simulation of WinUnisoft⁺ on their PCs to work with the same machine/tools/workpiece configuration and create their own programs.

The composition could include:

- Programming workstations with WinUnisoft⁺ working in simulation mode.
- PC controlled machines with WinUnisoft⁺ working in control mode.
- CAD/CAM software.

Virtool

Interactive virtual environment for training in the use of tool machines.

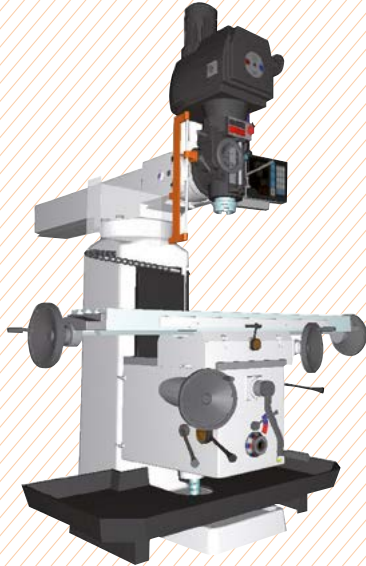

System based on interactive 3D graphs and virtual reality techniques which offer innovative possibilities for training.

VIRTOOL Machine is a software designed and developed for training in the preparation and use of swarf start up machines, both conventional and CNC.

With VIRTOOL Machine, students can carry out initial training with a virtual machine which will considerably reduce necessary work time when they move on to a real machine and will help them acquire and reinforce the basic concepts for preparation and machining on conventional and CNC machine-tool.

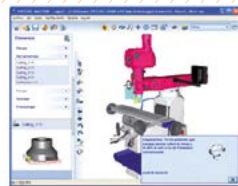

37 /

The virtual machines work just like the real machines. Each virtual machine, in 3D, is distributed with practice cases or case studies supported by a full set of theoretical content.

Learning by doing

The application is based on problem-based learning and enables independent study. Its advanced educational design is a result of the latest studies conducted in this field and the most up-to-date technology. (PBL Problem Based Learning, Self-Training, Learning by Doing).

Machines available 24 hours

It makes it possible to work on machines with low availability for an unlimited time.

Safe and indestructible machines

Reduces the risk of accidents and damage to the equipment during the training process.

Reduces the cost of the learning process

Reducing the time needed at machines and allowing a truly efficient learning process with less need for support from a teacher.

One machine, one student

It makes the work in the classroom and workshop more flexible, difficult to achieve when working in classrooms where there are only real machines.

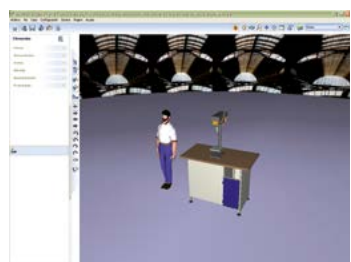

Working with a VIRTOOL Machine

The practical activity library, distributed with every virtual machine, is divided into case studies. The classification of cases dealt with is very complete and ranges from the identification of tools to the machining of complex parts, covering the handling of CNC controls.

With VIRTOOL Machine, the user/student performs the learning activities by solving case studies in a virtual environment. Users have all the information required for the case studies for each machine:

- A full description.
- Back-up materials.
- Instructions are constantly provided and errors notified, helping students to successfully solve all the case studies.
- Online reports can be obtained for student assessment by the tutors.

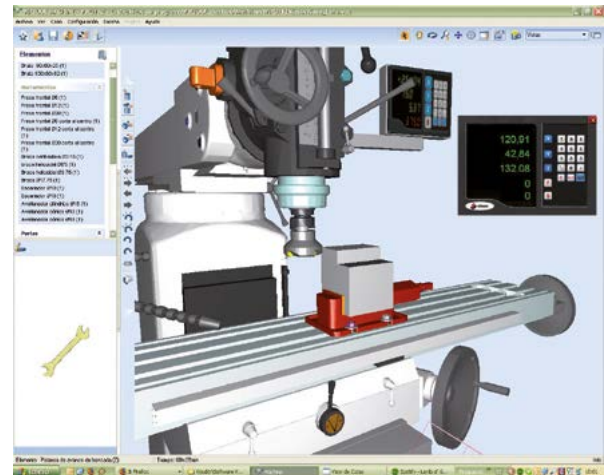

Interaction with the machine

It is performed through a series of operations which allow the student to machine complex parts:

- > **Select:** It allows user to identify elements.
- > **Assemble:** It allows the user to assemble an element on the machine or on another element shown in the scenario window.
- > **Dismantle:** It allows the user to dismantle, dismount or release an element from the scenario.
- > **Close:** It allows the user to tie or fix an element to another on the machine, using a tool if necessary.
- > **Open:** It allows the user to release or loosen an element on the machine, using the appropriate manual tool.
- > **Move:** To move the mobile elements sequentially or continuously.
- > **Machining.**
- > **Turn the part.**
- > **Dimension viewer:** Activates a dimension viewer that works like the real thing.
- > **CNC:** Activates the numerical control simulator for CNC machines. This control is handled and interacts with the machine in the same way as the real control.

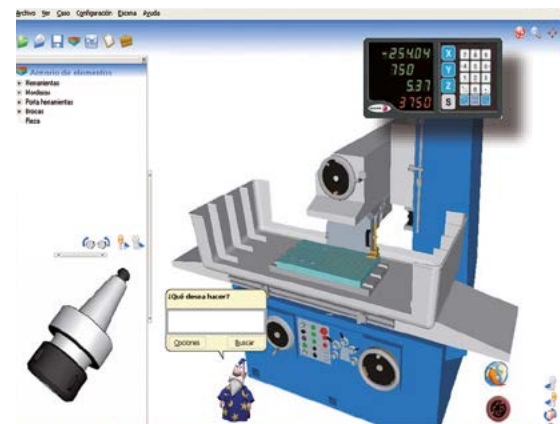

Moving in the 3d world or scenario

It is very simple and intuitive. It even includes pre-set displays to resort to if in need of a specific element.

VIRUFRE universal milling machine

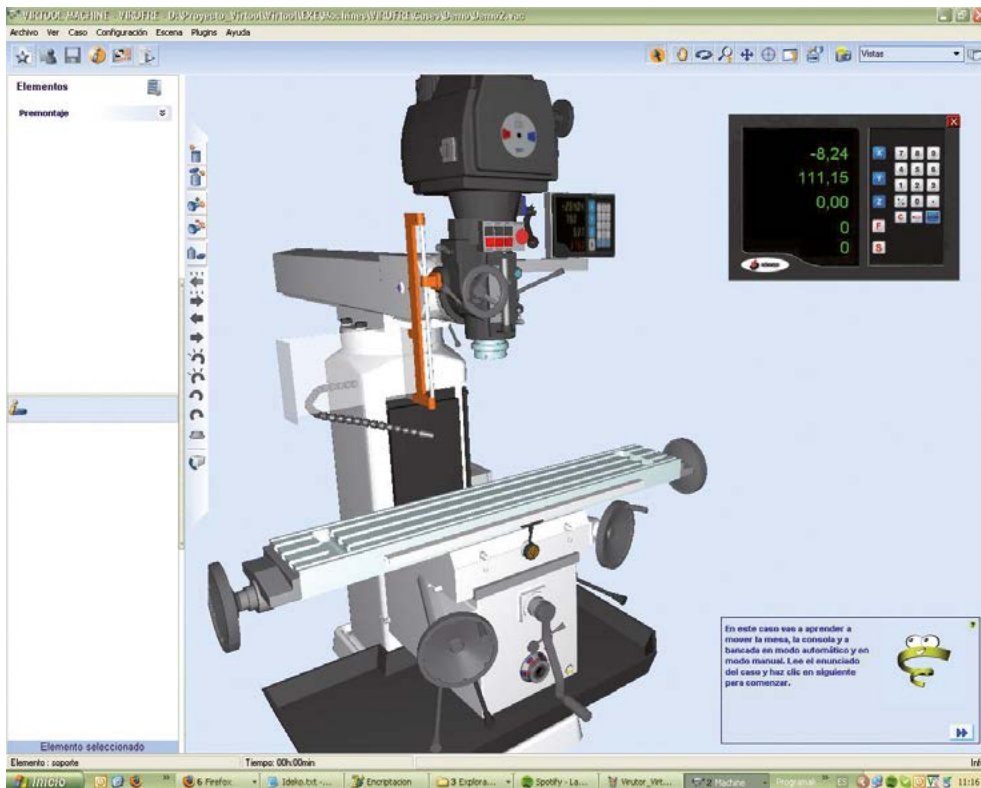

39 /



It is the VIRTOOL machine milling machine and with its set of exercises or case studies the student will be able to develop certain skills.

Each case study has a specific aim, studying everything from the machine components to the virtual performance of complex machining processes, highlighting:

- Identification of the machine parts.
- Understanding the dynamics of the machine.
- Types of fastenings and their elements.
- Assembly and adjustment of components.
- Identify and assemble tool holders, tools and auxiliary elements.
- Preparation for machining.
- Handling of the machine.
- Perform basic machining processes.
- Execution of machining processes.
- Complex machining processes.

VIRUTOR Parallel lathe



Virutor is the VIRTUOL conventional parallel lathe.

With this and the library of case studies it includes, the following is covered:

- Identification of the machine parts.
- Handling of the machine (movement of carriages, spindle movements).
- Identification and assembly of tools and tool holders.
- Types of fastenings, selection and assembly of parts.
- Calculation and establishment of cutting conditions.
- Safety elements.
- Identification and performance of machining processes.
- Execution of machining processes.

40 /

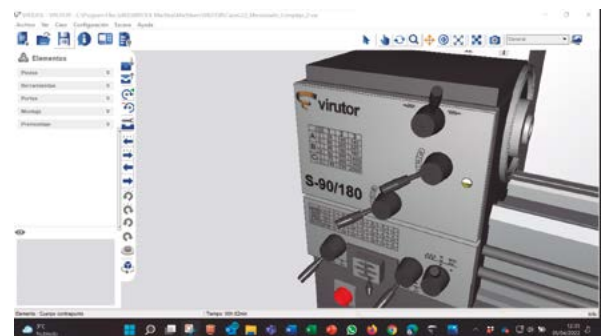

Licences system

Configure your own CLASSROOM



Configure your training classroom according to your needs at any given time. Choose and combine from the different protection methods available:

> **Web protection with three models.**

- Temporary 4 month license.
 - Temporary 1 year license.
 - Unlimited license.
- In this way you can adapt your resources to your requirements at all times and offer your students the possibility to acquire the product for their training period.
 - Each machine is licensed separately.

Babyplast 6/12

Plastics injection machine



41 /

An industrial machine adapted for training. Ease in implementation, simple programming via touch screen, proportional control on all axes, highly reliable and low maintenance.

Technical characteristics

Piston diameter (mm):	10	12	14	16	18
Injection pressure (KG/cm):	2,650	1,830	1,340	1,030	815
Closing force:	62.5 KN				
Opening force:	4 KN				
Opening travel:	30 -110 mm				
Expulsion Force:	7.5 KN				
Expulsion travel:	45 mm				
Hydraulic Pressure:	130 bar				
Oil tank capacity:	16 litres				
Cycle on empty:	2.4"				
Installed power:	2.95 kW				
Mould thickness:	70:135 mm				
Memorisation of parameters:	100 moulds				
Refrigeration open water circuit					
Refrigeration (optional):	closed table-cooling circuit				
Weight:	165 Kg				
Dimensions:	1,100 x 500 x 700 mm				
Supply:	3x 380 Vac (3 phases+neutral+earth)				

Babyplast is the result of over 10 years' experience in the field of micro-injection. It is specially adapted for training.

- Very easy programming through menus identifiable by icons.
- Synoptics, indicating the status of the sensors and actuators in real-time, allowing the monitoring of production.
- Compact, silent and clean.
- Easy to maintain: modular conception.

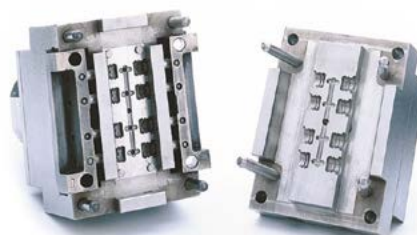

An industrial machine



An original mould system

- The housing and plates system is an integral part of the machine.
- Only the imprint block is interchangeable.
- The traditional structure of the mould is respected.
- The advantages of this device are:
 - Reduced cost of moulds.
 - Low production cost.
 - Precision of the parts produced.



42 /

- BABYPLAST 610 is a bench press which makes it possible to inject the majority of thermoplastic materials on the market: PP, PA, ABS, PS, PBT, POM, PPS.
- Totally hydraulic machine with supply unit, pump and deposit built in.
- Display manometers: injection pressure, mould closing pressure.
- Microprocessor of the control unit with colour touch screen.
- USB Connectivity and Ethernet.
- Five piston sizes for perfect adaptation to planned production.
- Control of all movements in closed loop by proportional control.
- It has two programmable outlets for managing cores, air streams, etc.
- Four heating areas with digital PID regulators.
- Control of cooling of four areas by flow meter.

Maximum security



- Emergency stop using push-button.
- Protective screen with detectors.
- Hydraulic safety which blocks any risk of movement when the guard is open.
- Protection of hot areas.
- Part recovery box and ramp for purge outlet.
- CE and CEM certification.

Assembly and mechanical maintenance

These assembly, repair and maintenance kits will allow students to know the main mechanical systems. Thanks to the cutting of each system it is possible to study each one of the different components and their operation.

The material is supplied placed and protected in a box for transport along with the necessary tools for its use.



MM01 – MOUNTING KIT: BALL GRAPH AND CLOSING VALVE Ref.: ZZM0156

43 /

The assembly, repair and maintenance MM01 kit allows to analyse the differences of a ball valve in front of a shut-off valve. Thanks to the cutting of each system it is possible to study each one of the different components and their operation. The material is supplied placed and protected in a box for transport along with the necessary tools for its use.



MM02 – MOUNTING KIT: PLUNGER COMPRESSOR Ref.: ZZM0157

The assembly bench MM02 contains everything necessary to introduce the student to a project of assembly of a compressor of plunger, object under study. The kit is supplied with two piston compressors: one under service conditions and one disassembled. In addition, the necessary tools are included for the assembly of the latter, so that is possible the analysis of the cutting at any time in front of the complete assembly. The bank also has drawers where to store the material, a front panel in which to place the necessary didactic material.

Other kits:

MM03: Assembly and Maintenance: Centrifugal Multi-Steel Pump

MM04: Assembly and Maintenance: Screw Pump

MM05: Assembly and Maintenance: Diaphragm Pump

MM06: Assembly and Maintenance: Plunger Pump

MM07: Assembly and Maintenance: Gear Pump

MM08: Mounting Kit: Hydrodynamics Slide Bearing

MM09: Mounting Kit: Shut-off Valve

MM10: Mounting Kit: Combined Gear

MM11: Kit Gate Flat Wedge Flap and Titled Seat Valve

ELECTRICAL TECHNOLOGY

There follows a presentation of the teaching aids for the study of electrical engineering from both an experimental and an analytical perspective, with the focal point or mainstay of the work being the “Analysis of Electrical Circuits”, addressing other blocks of content (Electromagnetism, Transformation, etc.) as and when they become important and relevant to the student’s teaching-learning process.

Teaching activities

These activities permit the instructor to organise different types of activities (demonstrations, explanations, etc.) for small or large groups. This means removing the traditional gap between classroom theory and workshop practice, integrating the entire process within a single physical setting.

44 /

Learning activities

These enable the student to undertake activities for analysing and experimenting with circuits, machinery and components. They include a series of technological features on a range of media that prepare the ground for the analysis and quick and reliable building of the circuits.

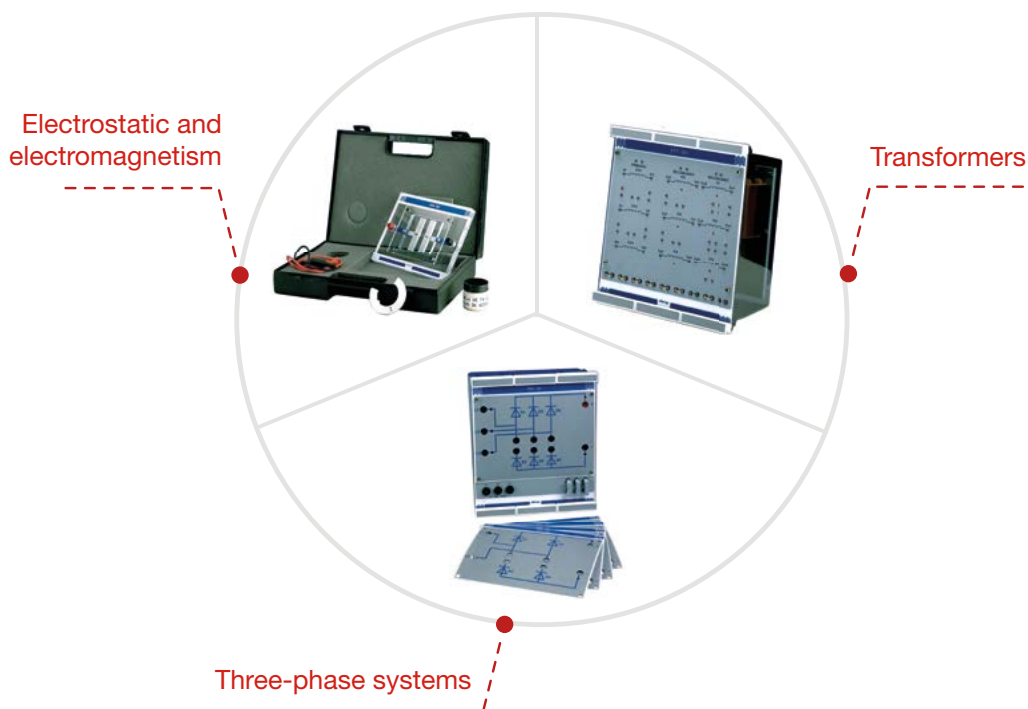



Documentation

A full array of documents, which in addition to the required user manuals for the equipment includes:

- The Teaching Guide: a description of the syllabus with the definition of goals, activities, scheduling, etc.
- The Handbook of Practical Activities, catering for the comprehensive use of the equipment in this catalogue.
- The Handbook of Content, as an introduction to the basics of electricity.

Auxiliary equipment

The laboratory can be fully fitted out with ancillary equipment, such as furniture, whiteboards, projectors, commercial instruments (multimeters, oscilloscopes, function generators), etc.

The ancillary equipment distributed by Alecop appears in full in the online catalogue (www.alecop.com).

Safety

All the equipment within the field of three-phase systems, transformation and the introduction to electrical machinery has been designed to operate at 22/38 V, with an assurance of safety for users that should be considered within its proper context: the operating voltages are 1/10th of the real ones (220/380 V).

Modularity

Each item of equipment in this catalogue has a modular arrangement in order to fulfil teaching requirements as per the user's needs.



ANG-800 didactic equipment for circuit analysis

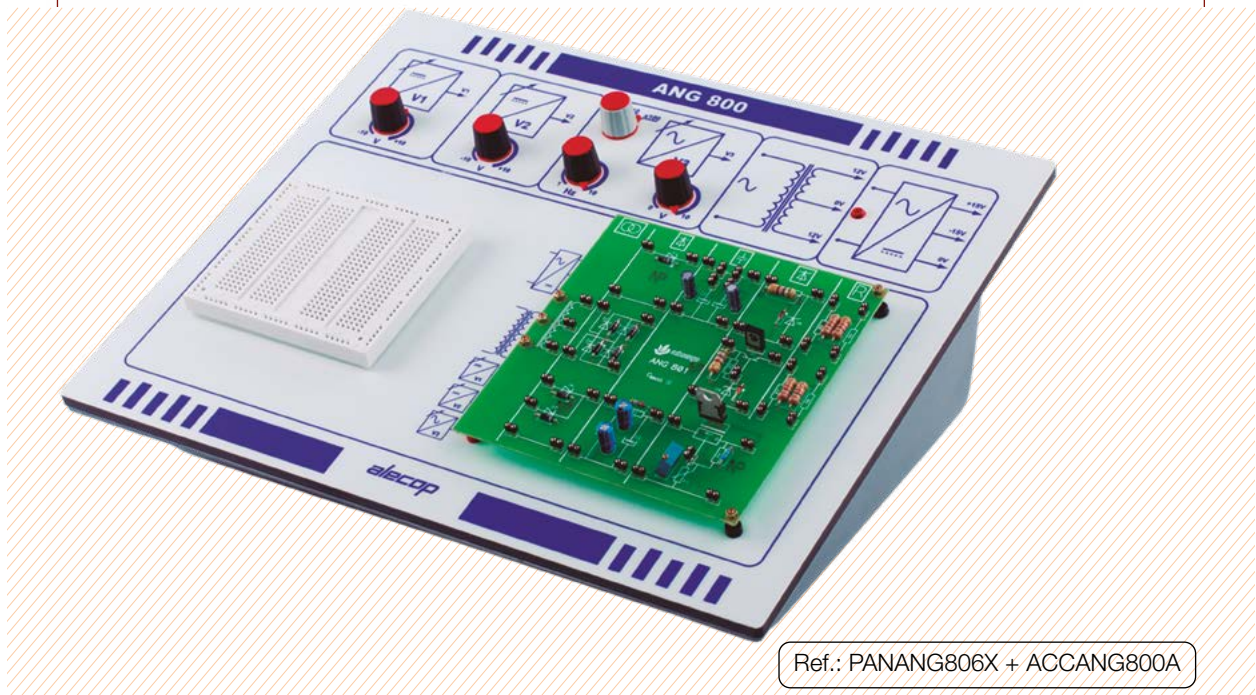

46 /

Modular trainer for the study of the basic principles of d.c. and a.c. circuits. The system is based on the ANG-800 console where the pre-constructed boards with the different systems of signal modulation and coding are placed. The console includes a prototyping area to allow for extra experiments and project work to be undertaken.

These trainers not only offer a convenient and robust platform, but also include all necessary power and signal sources. When the pre-constructed boards are inserted into the panel, the necessary connections to the power supply are made automatically keeping the number of required connections to a minimum. The only additional equipment required is an oscilloscope and a multimeter. They include a complete set of manuals for the teacher and students, as well as storage drawers, connection cables and components.

- Fixed dc source: $\pm 15V$ (I_{max} 0.5A).
- Fixed ac power supply (centre-tapped transformer) 12-0-12V (I_{max} 0.3A).
- Two variable voltage sources (V1 & V2) providing ± 10 volts dc (I_{max} 0.1A).
- Variable ac voltage source (V3) 0-10V and 1Hz-1kHz using variable and switched ranges.
- Board insertion area with 2mm sockets for boards fastening and power supply.
- 600-contact protoboard, for the realization of free-design circuits.
- Mains power cable.

This composition includes the set of cards and accessories for the study of DC and AC circuit fundamentals and theorems:

- ANG 800-DC1: DC fundamentals and networks theorems I.
- ANG 800-DC2: DC fundamentals and networks theorems II.
- ANG 800-AC1: AC Circuits I.
- ANG 800-AC2: AC Circuits II.

List of practices that can be performed with this equipment:

DC fundamentals and networks theorems I

- Basic DC circuit.
- OHM Law.
- Series circuit.
- Parallel circuit.
- Kirchoff's voltage law.
- Kirchoff's current law.
- Kirchoff's law combined.
- Thevenin circuits.
- Kirchoff with 2 sources.
- Superposition theorem.

DC fundamentals and networks theorems II

- Thevenizing a bridge circuit.
- Delta to star conversion.
- Charge and discharge of capacitors.
- Capacitors connected in parallel and series.
- Resolution of a DC circuit with capacitors.

AC Circuits I

- Sinusoidal waveform, AC values.
- Purely resistive AC circuit.
- Purely capacitive AC circuit.
- Purely inductive AC circuit.
- RC series AC circuits.
- RL series AC circuits.

AC Circuits II

- RLC series circuit.
- RLC series resonance.
- RC parallel circuit.
- RL parallel circuit.
- RLC parallel circuit.
- RLC parallel resonance.
- Low pass filter.
- High pass filter.

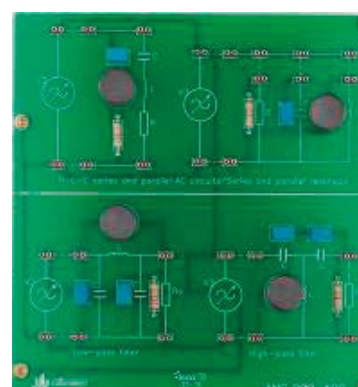
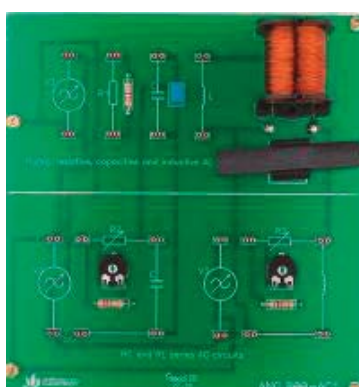
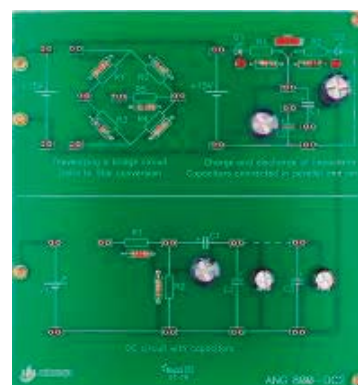
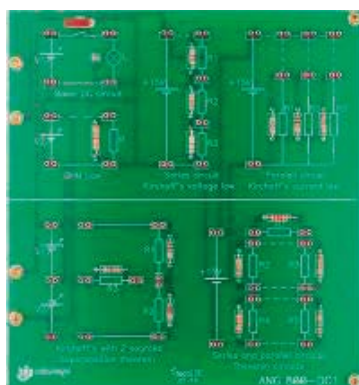

Electrostatics and



DIDACTIC ELECTROSTATICS KIT

Ref.: 9EQKEL1200

Carrier case for analysing electrostatic phenomena, which contains the following items:

- A cat-skin cloth.
- A cork ball frame.
- A PVC stick.
- A perspex stick.

Standard accessories included:

- User manual.

Recommended Optional Accessories:

- Coulombimeter COL-120.



DIDACTIC ELECTRICAL FIELD KIT

Ref.: 9EQKCE1200

This consists of a set of elements which are assembled by the user on a perspex base, which enable the force of a charge on an electric field, the principle of the workings of the condenser, etc., to be analysed. The phenomena can be observed on a screen with the aid of an over-head projector.

The elements included in the briefcase are:

- A base plate.
- 2 specific charge parts.
- 2 straight condenser parts.
- 1 cup part.
- 1 jar of semolina.
- 2 wires.
- 1 steel ball.

Standard accessories included:

- User manual.

NECESSARY accessories:

- FAT-120 high voltage source.

electromagnetism



DIDACTIC MAGNETIC FIELD KIT

Ref.: 9EQKCM1200

This is a set of elements which, once they have been assembled on a perspex base, allow the force lines of a magnetic field generated by different types of conductor elements to be analysed. The resulting phenomena can be visualised on a screen with the aid of an over-head projector. The various parts supplied with the briefcase include:

- A magnet base plate.
- A plain base.
- A straight-line current wire base.
- A spire plate.
- A coil plate.
- 4 20 x 40 mm magnets.
- 4 pieces of iron, 20 x 40 mm.
- 4 pieces of aluminium, 20 x 40 mm.
- 4 pieces of plastic, 20 x 40 mm.
- 1 jar of iron filings.
- 6 magnetised needles.
- 1 magnetised needle with frame.

Standard accessories included:

- User manual.

NECESSARY accessories:

- FAC-120 high voltage source.



HIGH VOLTAGE SOURCE FOR TEACHING PURPOSES

Ref.: 9EQFAT1200

A high voltage source that is fully protected to ensure user safety. It provides a direct voltage of up to 7,500 V that can be regulated by means of a potentiometer control, with a maximum current of 100 μ A. It has a digital display with a voltage reading. The power supply is 110-230 V / 50-60 Hz depending on the model.

Standard accessories included:

- User manual.

DIDACTIC HIGH CURRENT SUPPLY

Ref.: 9EQFAC1200

A source of high current set into a panel which can be placed on a frame or on a tabletop. It provides a current of up to 100 amp AC in the founder. Direct and alternating output, via separate sockets. A potentiometer allows you to vary the current. It has a visual display and special connectors for connecting different types of metal wires (for the analysis of heating, melting, etc).

Standard accessories included:

- User manual.
- Conductor materials: copper, nichrome and constantan.
- Fuses.

Three-phase systems

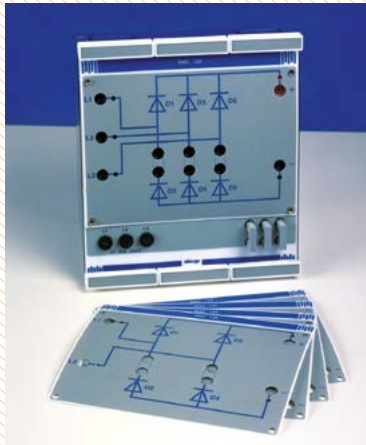

UNCONTROLLED SINGLE-THREE-PHASE RECTIFICATION

Ref.: MDULRNC120

There is a series of rectifier bridges incorporated onto a 6 power diode base (10A/600W) which are interconnectable and individually insulated against over voltage.

With the use of set of templates and connectors, it is possible to select and configure the various types of rectifier bridges which are under analysis:

- RNC-121 Template: medium wave single phase rectifier.
- RNC-122 Template: single phase bridge rectifier.
- RNC-123 Template: medium wave two-phase rectifier.
- RNC-124 Template: medium wave three phase rectifier.
- RNC-125 Template: three phase bridge rectifier.

The unit is designed to work on both standard as well as low voltage (22/38). There are high security 4mm bushes and 2m bushes provided for this, which also allow you to be able to measure the voltages and the currents of the circuits.

The unit s supply inputs are protected by 10A ultra-rapid fuses.

Standard accessories included:

- User manual.
- Connection bridges.

NECESSARY accessories:

- TRI-120 teaching module: three-phase transformer (for low voltage operation, if required).

BATTERY MODULE

Ref.: MDULBAT120



Modular item for simulating a back electromotive force, consisting of a 12 V, 6.5 Ah battery. The battery is charged internally by connecting the module to the power supply (110-230 V / 50-60 Hz depending on the module) and turning on the light switch. Safety bushings included.

Standard accessories included:

- User manual.

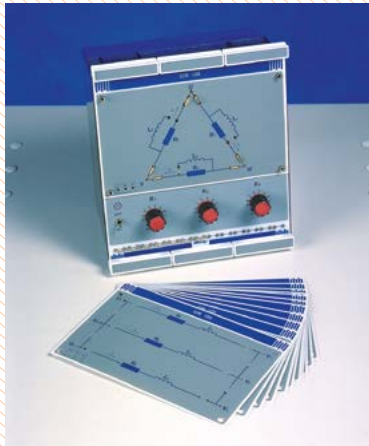

RESISTIVE-INDUCTIVE CHARGE

Ref.: MDULCIR120

This is a triple unit with three groups of R-L charges. Each group is composed of a 150mH/1A inductance and a 33 ohm/35W resistance in series with a rheostat of the same value. There is protection against over current measured at 1A for each group. The maximum charge applicable is 50Vef.

Using a different multi-template and jumpers, you can select the type of connection charges and the desired work. The use of cables in the assembly is minimal.

The template collection includes:

- CIR-121 Template: Charge R free connection.
- CIR-122 Template: Charge L free connection.
- CIR-123 Template: Charge R-L free series connection.
- CIR-124 Template: Charge R-L free parallel connection.
- CIR-125 Template: Charge R triangle connection.
- CIR-126 Template: Charge L triangle connection.
- CIR-127 Template: Charge R-L triangle series connection.
- CIR-128 template: parallel RL load delta connection.
- CIR-129 template: Charging R star connection.
- CIR-130 template: Cargo L star connection.
- CIR-131 template: Load RL series star connection.

Standard accessories included:

- User manual.
- Connection bridges.

NECESSARY accessories:

- TRI-120 teaching module: three-phase transformer.



CAPACITIVE CHARGE

Ref.: MDULCRC120

This is a triple modular frame which incorporates a series of condensers grouped electrically into three groups: C1, C2, and C3. By means of a set of templates (3) and connectors (no more than three), it is possible to configure:

- CRC-121 Template: Free connection.
- CRC-122 Template: Star connection.
- CRC-123 Template: Triangle connection.

Each group of condensers can adopt capacities of 1, 5, 10, 25, 50 and/or 100(F which can be selected by means of a change-over switch. The maximum working voltage of each group is 63V.

Standard accessories included:

- User manual.
- Connection bridges.

Recommended Optional Accessories:

- Instrumentation: voltmeter, ammeter, phase meter, ...

NECESSARY accessories:

- TRI-120 teaching module: three-phase transformer.

Transformers



SINGLE-PHASE TRANSFORMER AND ELECTROMAGNETISM KIT

Ref.: 9EQKTM1200

A kit for assembling and studying different types of single phase transformers. It enables you to analyse the principles of electromagnetism: the functioning of a relay, of a bell, ...

It consists of a triple unit for a assembly base and a briefcase which contains the various construction elements such as:

- A U nucleus.
- An I nucleus with an air gap variation control.
- 2 x 500-spire coils.
- 2 x 250-spire coils.
- 2 x 100-spire pendulum coils.
- Pendulum sheet (relay, bell, etc.).
- Bell ringer.
- 2 frames (relay contact).
- Pendulum arm (Foucault).
- Magnets.
- Various parts (pieces of iron, aluminium, etc.).

Standard accessories included:

- User manual.

THREE-PHASE TRANSFORMER 230/400-22/38V

Ref.: MDULTRI122

Ref.: MDULTRI123

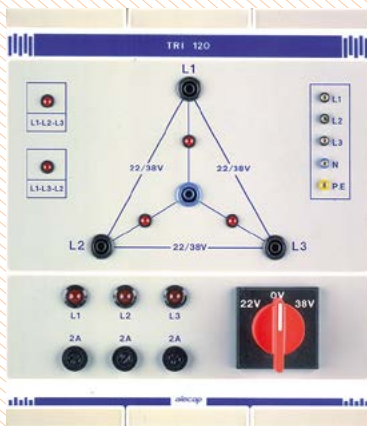

This is a three-phase transformer which, depending on the model (TRI-122 or TRI-123), has a transformation ratio of either 220V to 22/38V or 380V to 22V-38V, with an apparent power of 300 VA.

The output voltage is 22V between phases (12.7V neutral phase) and 4 Amperes or 38V between phases (22V neutral phase) and 3.75 Amperes which can be selected by means of a commutator on the front template.

The output is by both 4mm and 2mm bushes and they are protected against overcurrent and shortcircuit with a light indicator per phase. They are thermally insulated with resetting being produced automatically after the protective elements have been cold for a period of time.

The frontal light display shows the order of phases (L1-L2-L3 or L1-L3-L2).

The transformer primary is protected by 2A fuses with a light indication if any should blow (pilot light out).

Standard accessories included:

- User manual.



SINGLE-PHASE AUTOTRANSFORMER

Ref.: MDULAUT120

Single-phase autotransformer with 230 V / 50-60 Hz input voltage and variable output adjusted by a potentiometer control.

- Maximum output voltage: 250 V.
- Maximum output load: 1 A.
- Protection: 1 A fuse.
- Safety bushings.

Standard accessories included:

- User manual.



THREE-PHASE TRANSFORMER STUDY

Ref.: MDULETT120

Equipment for analysing the different types of connections on three-phase transformers.

It is composed of an ETT-120 three-phase transformer multitemplate unit and a set of 12 templates.

The unit incorporates three single phase transformers, each of which has two secondaries of an identical transformation ratio (0.5/1). The nominal voltage for the primary windings is 22v and 11V for the secondary ones.

By means of the templates (12), and connectors (never more than 9), the following three-phase transformer configurations may be obtained:

- T-E-1 Template: Triangle-Startime phase difference 1.
- T-E-5 Template: Triangle-Startime phase difference 5.
- T-E-11 Template: Triangle-Startime phase difference 11.
- T-2E Template: Triangle-Double Star.
- T-T-0 Template: Triangle-Triangle-time phase difference 0.
- T-Z-0 Template: Triangle-Zig/Zag-time phase difference 0.
- E-E-0 Template: Star-Star- time phase difference 0.
- E-E-6 Template: Star-Star- time phase difference 6.
- E-T-5 Template: Star-Triangletime phase difference 5.
- E-T-11 Template: Star- Triangletime phase difference 11.
- E-Z-5 Template: Star-Zig-Zagtime phase difference 5.
- E-Z-11 Template: Star-Zig-Zagtime phase difference 11.

The input/output terminals are printed on all the labels. Each one of the six secondary windings is fitted with a thermal protection circuit with a light indicator, set at 0.65 A.

Required accessories:

- TRI-120 three phase transformer didactic module.

4 electrical machines

Educational resources for the study of electrical, static and rotary machines. Ranging from the operating principles to the construction of automatic devices and the maintenance operations of the machines.

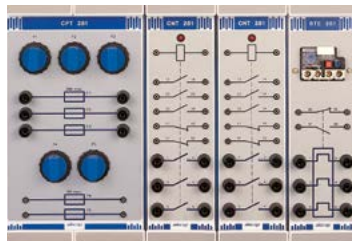

AUTOMATION



WORKSHOP

Electrical machines



TESTING



PRINCIPLES



CLASSROOM-WORKSHOP



55 /

Documentation

Each resource has a set of supporting documents to facilitate the teacher's work:

- **User Manual:** contains instructions for the implementation and operation of equipment, its technical features and information about precautions to be taken into account for proper operation.
- **Workbook:** Defines the objectives, sequence of implementation and an answer key for each of the practice sessions.

Safety

The resources presented in this catalogue have been designed to meet European directives on the safety of machinery, low voltage and electromagnetic compatibility.

Economics

The scalability of the teaching resources and the potential for use in the classroom, allows a considerable reduction in the investment to be made for a specific program of electrical machines.

Modularity

The equipment allows a modular configuration according to the available equipment and the training needs of the user.

ProLAB

Modular test bench

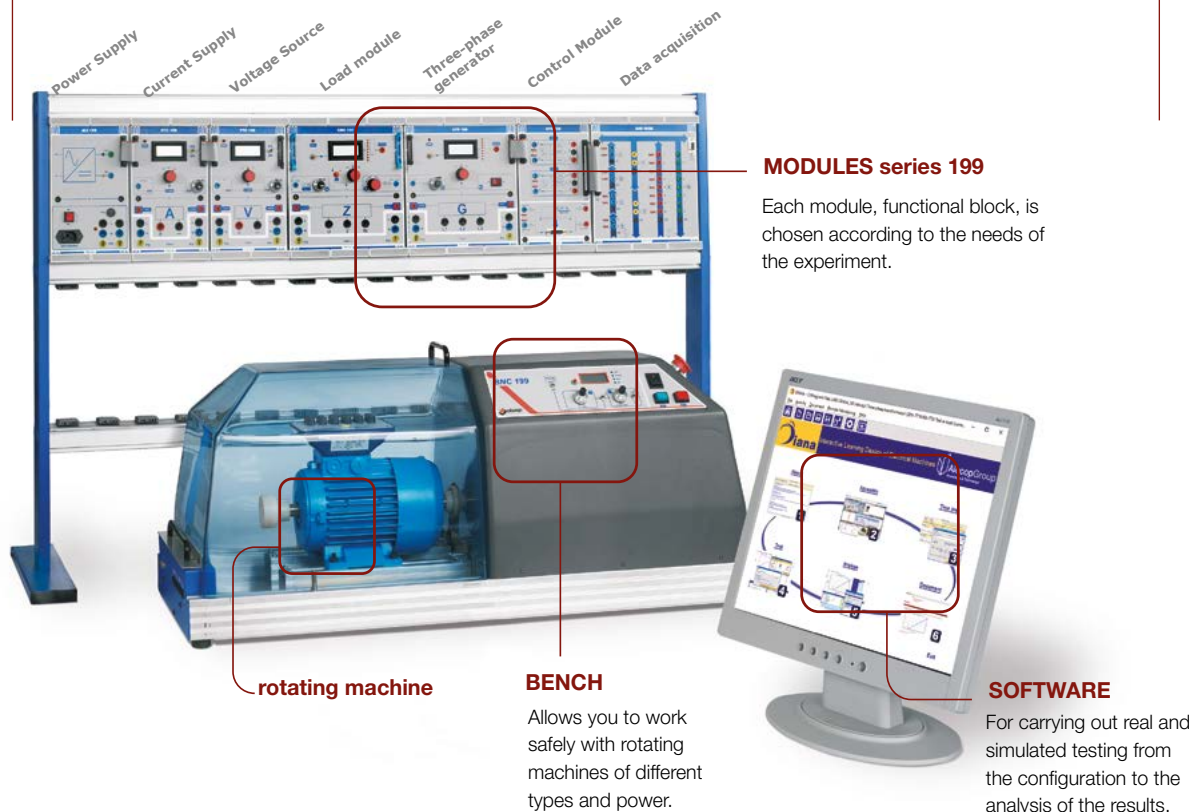

56 /

Alecop's **ProLAB** is the most advanced system for teaching Electrical Machines. It allows students to study, both theoretically and practically, the operation and performance of static and rotating electrical machines from a fundamental level to the most advanced tests.

ProLAB is a modular system, comprising a test bench, power supplies, instruments and various dc, single and 3-phase ac machines and transformers. It can be configured traditionally as single workstations, using either conventional or PC based instruments, or networked when only one set of hardware is necessary for each classroom providing a cost effective solution, and a simple upgrade path when student numbers increase.

When used with a PC or networked, **Diana software** provides theory and instruction, as well as control, and guides the student through the construction and assembly of different test strategies. Even complex configurations take only minutes to complete. Diana contains standard test routines or allows the student or instructor to set up their own experiments.

Each of the modules, whether power supplies, loads or instruments can be set up manually or via the software. The machines and test bench are also compatible with conventional instruments.

Uniquely **Diana** contains mathematical models of each machines so the 'ideal' simulated test results can be directly compared to those obtained from real machines. Alternatively students can familiarise themselves with test procedures using the simulation before moving on to the actual machine. A document generator helps students produce their laboratory reports. Comprehensive documentation is provided with experimental manuals for both the student and instructor.

ProLAB can be mounted, when required, on a mobile bench for portability. Because it only requires a single phase power supply (three phase for machine operation is generated on-board), it can be used in any classroom so the days of costly dedicated laboratories are past.

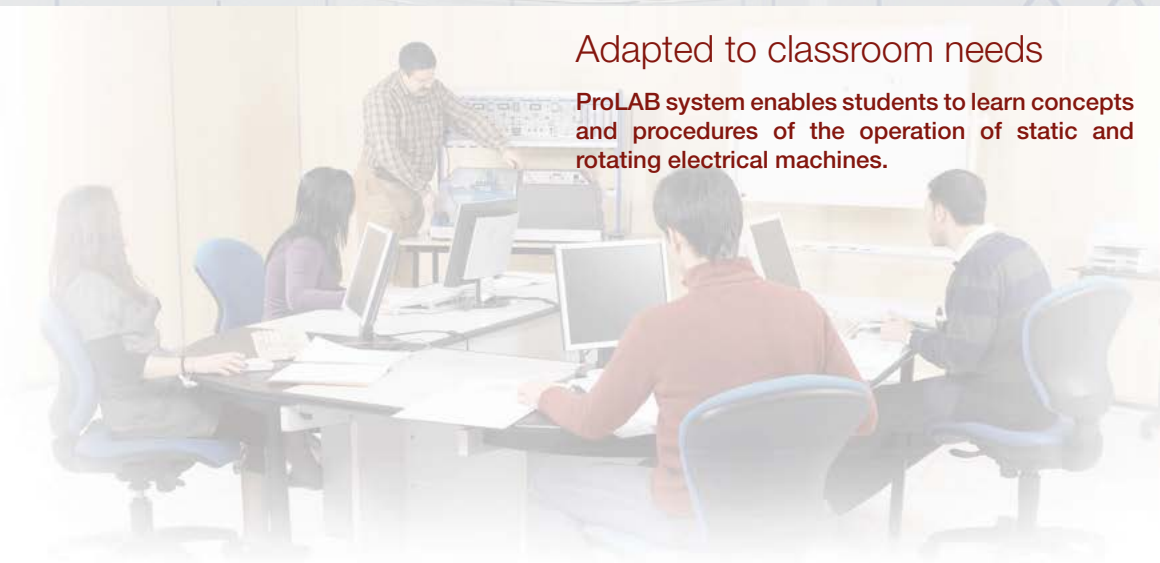

Adapted to classroom needs

ProLAB system enables students to learn concepts and procedures of the operation of static and rotating electrical machines.

Scalability

The modular system makes it possible to acquire the components that best meet the needs of its centre, for both curriculum and budget. ProLAB is compatible with conventional elements in your classroom/workshop (resistors, inductors, capacitors, rectifier bridges, etc.).



57 /

Time and motion economy

One machine per class is sufficient, reducing acquisition and maintenance costs.

The “199” module series, designed for this system has standard instrumentation built in.

The most complex assembly takes only a few minutes and with few cables.



ENVIRONMENTALLY FRIENDLY PRODUCT

The equipment returns the energy to the grid that is traditional dissipated into heat. In addition to reducing consumption, it implies the reduction of the size of the modules and bench, and the elimination of potentially dangerous hot spots.



SAFETY

This equipment goes beyond the current regulations relating to safety, implementing a series of added protection to prevent accidents in the field of education.

Work process

ProLAB allows the student to put into practise the basic concepts learnt in the theory related to the operation of electrical machines. The putting into practise is by testing, whether real or simulated. Each test is performed following these 6 steps:

58 /

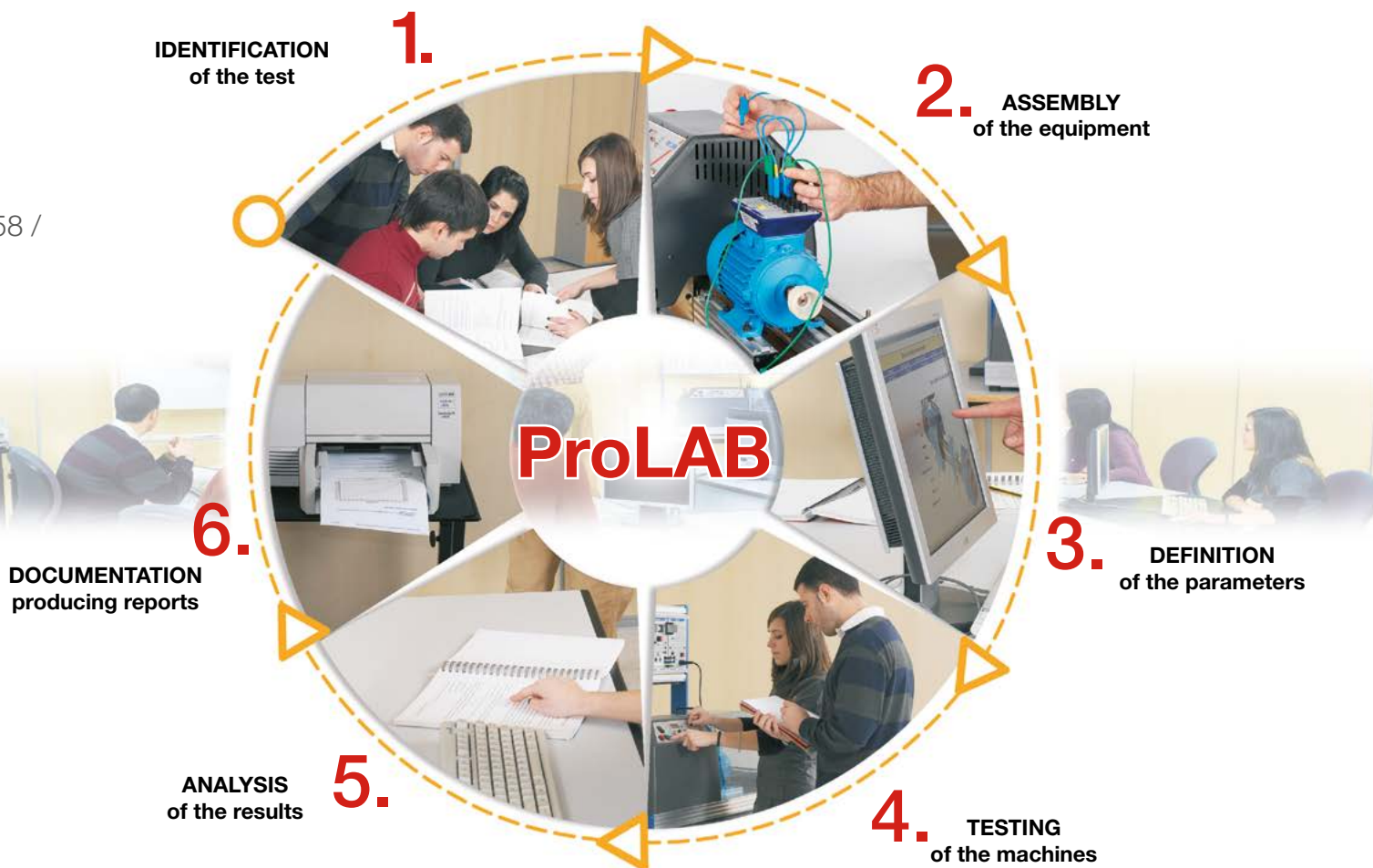

Classroom work

1. Manual



Testing with the modules and the bench. Fieldwork. Manual demonstrations.

2. Mixed



Combines the use computer to prepare exercises and sending the manual application, to the machine bench.

3. Simulation



Enables the entire work process to be carried out through the software. The library has the most significant test activities to achieve global learning.

Configuration

Students in the class are kept active thus avoiding, as far as possible, waiting times. Classroom connectivity completes the work:



simple

non-networked, students work individually on their computers and run the test manually or from the teacher's computer.



in network

Having a local area network enables tests to be carried out from any computer using DIANA.



internet

If Internet is added, the users who are not physically in the classroom, may access the test bench thus facilitating distance learning.

Bench

Independent bench for testing rotating electrical machines

Ref: 9EQBNC199A



FUNCTION. Test traction motor and machine brake.

60 /

At the heart of the system is the BNC-199 Machine Test Bench into which various motors under test are mounted. This can be manually operated or computer controlled. In Dynamometer mode real time measurements of Speed, Torque and Power are displayed or it can be used as a prime mover for Generator tests. All parameters are also available on the external connector.

Safety is of paramount importance. Interlocks ensure machines cannot be operated unless the robust transparent safety cover is in place. Voltages are isolated and any fault condition, such as over or under voltage, excessive speed or torque etc, are indicated and operate protective relays.

Technical specifications

GENERAL

Dimensions: 950 x 360 x 420 mm

Weight: 41 Kg

Power supply: Single phase network 190 to 250Vac - 5.25 Amp. - 50/60Hz

Machines type to be tested:

- Foot height type 71, 80 and 90 mm.

- 80 and 90 mm height on Alecop profiles.

The testing machine is attached using elastic coupling.

OPERATING AS A TRACTION MOTOR

Speed: 0 to 2,000 rpm

Rated: 800 W

Maximum torque: 9.7 Nm

OPERATING AS A BRAKE

Maximum speed: 2,450 rpm

Torque: 0 to 10 Nm

Rated: 800 W

PROTECTIONS

Mobile protection with electric anchor.

Emergency stop button on the bench.

4mm safety terminals for the connection of the machine under testing.

Internal protections: internal temperature, torque, speed, insufficient voltage, excessive over voltage and grid over-current.

Module

ALI-199

Power Supply Module

Provides $\pm 15V$ power for all the other ProLAB modules fitted to the frame and single phase voltage via 4mm safety terminals.

Ref: MDULALI199

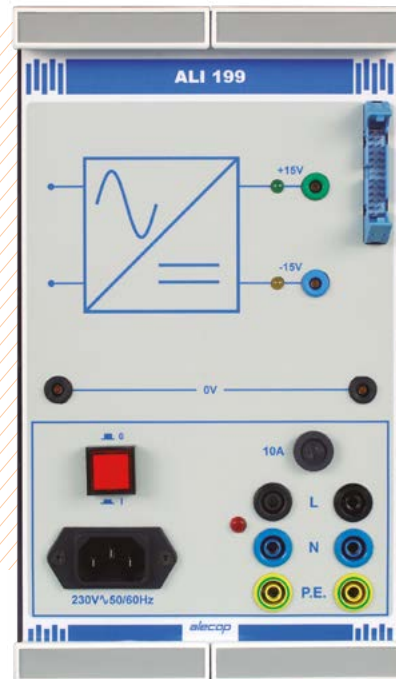

61 /

Functional description

The support comprises a double-size training module: 250 x 144 x 130 mm.

The power required for its operation is:

- Voltage: 190 ÷ 250 Vac 50/60Hz.
- Maximum power: 1 kW.

Includes serigraph identifying the functional blocks and components symbols.

Uses 2 mm. in diameter safety sockets which serve as testing points and 4 mm safety sockets diameter for the power supply (red).

Technical specifications

Input supply voltage: Single-phase 190 to 250VAC using a socket.

Mains Frequency: 50Hz / 60Hz.

Output voltage: $\pm 15V$ c.c.

Maximum current: 2 Amp.

Protections:

Input: using 10amp fuse.

Output: Thermal Protection calculated at 2 Amp.

Outputs from the source: Using the frame chassis and 2mm safety plugs.

Indications: On light to indicate main supply and outputs from the active source.

Module

FTC-199

Adjustable DC Voltage source

DC power supply can be controlled manually, externally or via PC. Includes a switchable display and proportional outputs.



Ref: MDULFTC199

62 /

Functional description

The support comprises a double-size training module: 250 x 144 x 130 mm.

The power required for its operation is:

- ± 15 V., 15 V, by plugging into the ALECOP support frame.
- Voltage: 190 ÷ 250 V.
- Maximum power: 1 kW.

Includes serigraph identifying the functional blocks and components symbols.

Uses 2 mm. in diameter safety sockets which serve as testing points and 4 mm safety sockets diameter for the power supply (red).

Technical specifications

The module includes a continuous voltage source whose characteristics are:

Output voltage variation: 0 ÷ 250 V.

Output current: 6.6 A max.

Types of settings:

- Interior: with a dial.
- Exterior: Using a DB26 with a safety socket of 2mm.

Accuracy: 1%.

Physical Measurements:

Magnitude display:

- Magnitudes displayed: Current and voltage output (can be selected using a switch) on the 3½ digit display.
- Voltage Range / Precision: 0 ÷ 250 V c.c. 1% F.E.
- Current Range / Precision: 0 ÷ 6.6 A < 1% F.E.

Magnitude signal capture:

- Analogue signals in the DB26 connector: Output voltage and current.
- Analogue signals in the sockets: output voltage and current.
- Voltage range / precision: 0 ÷ 250 V c.c. (0 ± 10 V) 1% F.E.
- Precision current range: 0 ÷ 6.6 A c.c. (0 ± 10 V) 1% F.E.

Incorporates electronic protection, protecting the module against overloads and short circuits.

Module

FCC-199

Adjustable DC Current source

DC power supply providing controlled current output. Includes a switchable display and proportional outputs.

Ref: MDULFCC199



63 /

Functional description

The support comprises a double-size training module: 250 x 144 x 130 mm.

The power required for its operation is:

- ± 15 V., by inserting into the ALECOP support frame.
- Voltage: 190 ÷ 250 V.
- Maximum power: 1 kW.

Includes serigraph identifying the functional blocks and components symbols.

Uses 2 mm. in diameter safety sockets which serve as testing points and 4 mm safety sockets diameter for the power supply (red).

Technical specifications

The module includes a voltage source whose characteristics are:

Output voltage variation: 0 ÷ 310 V.

Output current: 0 ÷ 3.3 A.

Types of settings:

- Interior: with a dial.
- Exterior: Using a DB26 with a safety socket of 2mm.

Accuracy: 1%.

Physical Measurements:

Magnitude display:

- Magnitudes displayed: output voltage and current. (Switch selectable) in a 3½ digit display.
- Voltage range / precision: 0 ÷ 310 V c.c. 1% F.E.
- Current range / Precision: 0 ÷ 3.3 A c.c. < 1% F.E.

Magnitude signal capture:

- Analogue signals in the DB26 connector: Output voltage and current.
- Analogue signals in the sockets: output voltage and current.
- Voltage range / precision: 0 ÷ 350 V c.c. (0 ± 10 V) 1% F.E.
- Precision current range: 0 ÷ 3.5 A c.c. (0 ± 10 V) 1% F.E.

Incorporates electronic protection, protecting the module against overloads and short circuits.

Module

CRG-199

Electronic load

Ref: MDULCRG199

A compact DC, single and three-phase electronic load for rotary machines and transformers. Reactive and resistive loads with a Power Factor between 0 and 1 (inductive or capacitive). Ability to capture and control magnitudes by PC via a data acquisition system and DIANA software. The incorporated controls allow it to operate in accordance with the various types of passive loads:

- Direct current resistive load.
- Inductive load - resistive – single-phase capacitive.
- Inductive load - resistive –three-phase capacitive.
- Power factor variable between 0 and 1 (inductive and capacitive).



64 /

Functional description

The support comprises a triple-size training module: 250 x 216 x 130 mm.

It operates installed in a desktop vertical rack from where it gets its ± 15 V power required for operation. Interconnection with other modules in the test bench BNC-199 and DIANA software with a fast 26-pin connector.

2 mm sockets for external measurements and set values. 4 mm safety terminals input power (mains connection). Includes serigraph identifying the functional blocks. Has many advantages over other traditional load types (resistors, capacitor banks, inductances, etc.), Including the following:

- Reduced volume: all possible load types in one module.
- Improved Performance: Incorporates electronic circuitry which returns the energy to the power supply.
- Safety: Incorporates protection against overloads and short circuits, as well as safety terminals for user protection.
- Accuracy and resolution: Electronic control of electrical magnitudes (current amplitude and power factor).
- Instrumentation built into the module itself.
- Interconnection with other elements of the Test Bench BNC-199 tests and control from the PC with DIANA software.
- Possibility of autonomous operation with manual or computer assisted control (general purpose data acquisition system).

Technical specifications

Power supply:

- Control: ± 15 VDC from the ALE COP support frame.
- Power: Single phase 190 to 250 Vac across safety terminals.

Maximum power:

- 1 HP Direct Current.
- 1 HP single phase alternating current.
- 1 kW three-phase alternating current.

Power factor: Variable between 0 and 1 (inductive and capacitive).

Maximum input voltage:

- 250 V Direct Current.
- 280 V AC single and three phase.

Maximum intensity: 10 A.

Short-circuit switch: Current variation between 0 and 100%.

Module with integrated Instrumentation through LCD display and magnitude selector push button:

- Voltmeter.
- Ammeter.
- Wattmeter (active, reactive and apparent).
- Power Factor Meter.
- Phase angle meter to measure the angle between voltage and current.
- Frequency.

Module

GTP-199

Three-phase Power Generator

Provides adjustable three-phase power for rotary machines and transformers from a single-phase input. Includes adjustable Power Factor and a switchable display.

Works autonomously or is able to capture and control magnitudes by PC via a data acquisition system and DIANA software.

Ref: MDULGTP199

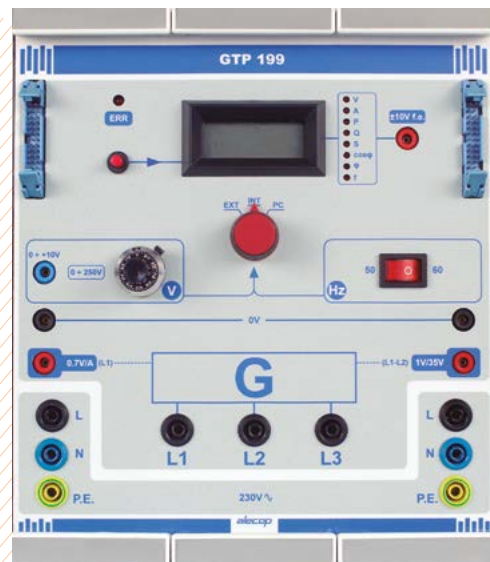

65 /

Functional description

The support comprises a triple-size training module: 250 x 216 x 130 mm.

It operates installed in a desktop vertical rack from where it gets its ± 15 V power required for operation.

Interconnection with other modules in the test bench BNC-199 and DIANA software with a fast 26-pin connector. 2 mm sockets for external measurements and set values. 4 mm safety terminals input power (mains connection).

Includes serigraph identifying the functional blocks. Has many advantages over other types of variable voltage (auto-linear drive frequency, etc...), Among which are the following:

- Reduced volume: Single and three-phase generator with its instrumentation in a single module.
- Improved performance: incorporates power electronic circuits returning power to the mains.
- Safety: Incorporates protection against overloads and short circuits, as well as safety terminals for user protection.
- Accuracy and resolution: electronic control of electrical quantities (voltage amplitude).
- Instrumentation built into the module itself.
- Interconnection with other elements of the BNC-199 Test Bench and control from the PC with DIANA software.

Possibility of autonomous operation with manual or computer assisted control (data acquisition system for general use).

Technical specifications

Power supply:

- Control: ± 15 VDC from the ALECOP support frame.
- Power: Single phase 190 to 250 Vac using safety terminals.

Maximum power: 1 kW.

Power factor: Variable between 0 and 1 (inductive and capacitive).

Maximum output voltage: 250 V AC.

Maximum intensity: 10 A.

Module with integrated Instrumentation through LCD display and magnitude selector push button:

- Voltmeter.
- Ammeter.
- Wattmeter (active, reactive and apparent).
- Power Factor Meter.
- Phase angle meter to measure the angle between voltage and current.
- Frequency.

Incorporates electronic protection, protecting the module against overloads and short circuits.

Module

CTR-199

Interface to the Test Bench

Full computer control to configure different tests and mathematical functions to calculate true rms values and power factor.

Union between BNC-199 bench and test bench, allowing set values to be applied to the bench and their signals to be read.

- Two blocks are available to calculate the true efficient values of two signals and the power factor between them.
- Organizes the analogue inputs and outputs of the SAD450 DIANA as needed by the DIANA software for automatic configuration of the test.

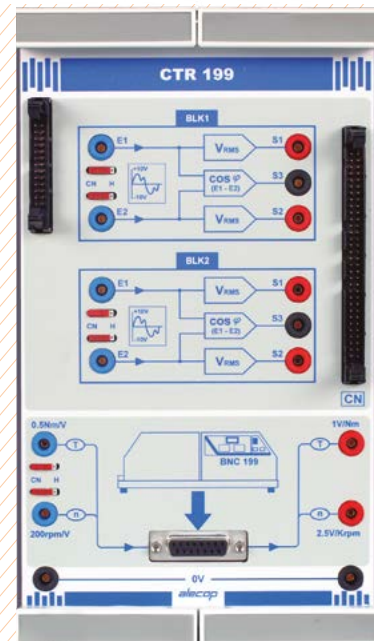

Ref: MDULCTR199

66 /

Functional description

The support comprises a double-size training module: 250 x 144 x 130 mm. The power required for its operation is:

- ± 15 V, by inserting into the ALECOP support frame.

Includes serigraph identifying the functional blocks and components symbols. Use safety sockets 2 mm. in diameter that serve as test points.

Technical specifications

True effective value block

- Number of inputs: 2 (Two effective values). ± 10 V.
- Number of outputs: 3 (Two effective values 0 to +10V, and an out of phase Cosine ± 10 V).
- Bandwidth: >500Hz.
- Accuracy: 1% f.e. (RMS), 2% f.e. (power factor).

BNC-199 connection

- Number of active signals: 6.
 - Number of outputs (default value): 2 (Torque and speed).
 - Number of inputs (measurements): 2 (Torque and speed).
 - Number of control signals: 2 (Error and Control).
- 2 mm safety plugs for set point control or testing.

Input-output control

- Number of modules to control: 4 + BNC199 Test benches + 2 RMS blocks.
- Number of combinations: 128.

Module

SAD450M

PC Control Module

Full computer control to configure different tests and mathematical functions to calculate true rms values and power factor.

Along with the DIANA software it is part of a test bench governed from a computer which enables tests to be performed on real machines (transformers, DC rotary machines, and AC single and three phase rotary electrical machines). This module requires a desktop chassis with power supply (ALI -700 or ALI-199) for its operation. It has inputs / output connections in 2 mm sockets to connect quickly with the equipment to be analyzed. In addition to the sockets, all connections are available in a 64-way connector.

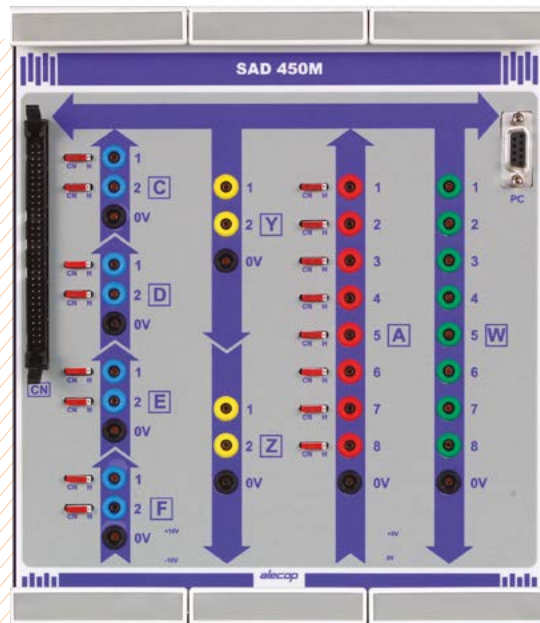

Ref: MDULSAD450

67 /

Functional description

Along with the SAD-450 a module a cable for a line connection to a PC USB is incorporated. The SAD450 module is divided into 8 blocks or channels, each with a determined I / O type and with different nomenclature based on whether they are inputs or outputs.

Each analogue or digital input channel has a switch to select whether the input comes from the socket (position H) or a 64-way connector (CN). Based on this switch the origin of the signal to be acquired by the data acquisition system will be determined.

The outputs have no switch and will be accessible both from the socket and from the connector at all times.

Technical specifications

Communication via ASCII commands

Consumption: +15V – 162mA.

Physical Measurements: 215x250x147 mm. (W x H x D)

External connections:

- PC connection: USB wire.
- Power Supply Connector to the frame.
- I/O Connector: 64-way connector.

Conversion times:

- 1 channel analogue Fmax 200 KHz.
- Fmax 1 digital channel 333 KHz.

60K of RAM for data

8 Analog Inputs: 12 bits of resolution.



Diana software can be used with a stand-alone PC, networked or over the Internet. It not only controls the test bench and machines under test but also includes powerful mathematical models which allow the comparison of real world results with simulation. Students can familiarise themselves with experimental procedures before entering the laboratory.

A truly comprehensive package Diana's features include:

- Theory and experimental procedures.
- Configurable mathematical models of DC and AC machines.
- Assembly instructions and graphics for experiment set-up.
- Definition of all experimental parameters.
- Control of all modules and the test bench parameters.
- Realtime display of experimental results.
- Analysis of experimental results; using both real machines and simulation.
- A report generator for the production of post experiment documentation.

68 /

When used over a network Diana allows multiple students to interact with one set of hardware reducing costs and providing a scalable environment for studying machines.



simple



in network



internet



CONDUCTING A TEST

- 1. Description of the test**



You can enter a title and description that includes images about the practice.
- 2. Definition of assembly**

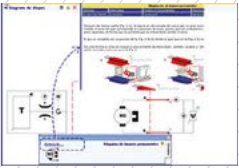

The items chosen as part of the test, their interconnection and instrumentation through a block diagram.
- 3. Real elements**

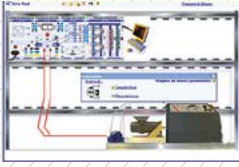

The block diagram is translated to real elements DIANA offers various possibilities for each element and shows how to do the actual connection.
- 4. Chronogram**

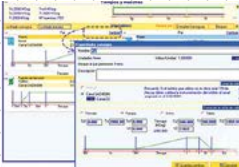

The signals which are sent and received from and to the test elements are configured in this section (units, signal shape and its timer).
- 5. Performing the test**



Once the definition of the test is complete it can be launched and the status of the signals of interest can be monitored.
- 6. Test bench Network**



The test is applied and transmitted to a ProLAB through the local network or Internet.

Local test bench



ProLAB is connected to the PC directly.

Simulated test bench



Advanced machine simulators incorporated by DIANA offer a result tightly adjusted to reality without the need for any hardware.
- 7. Analysis of the results**



In each test a set of signals are collected a signal that is stored in the results. With DIANA signals can be viewed, compared, operations can be carried out among them and filters can even be applied.
- 8. Document**



A DIANA wizard generates personalised reports on the work carried out with graphic and numerical information.

69 /

Includes a comprehensive library of activities

It is not necessary to start from scratch to set up the tests. DIANA is distributed with a complete library of activities designed and developed by experts, including:

- Headings.
- Configuration of items.
- Definition of the diagram.
- Results analyzed with comments.

Tests for AC, DC electric machines and transformers.

Licensing system

DIANA licenses can be hardware or Internet licenses:

- Web Licenses
 - Undefined
 - 1 year
 - 4 months

[DIANA is full of content on electrical machines!]

Automation

Control and testing with electrical machines CM-281

Designed to study the operating principles of electric machines, allows for commissioning, testing on empty and loaded to obtain curves, etc.

It is composed by:

- 1 Set of didactic modules of instrumentation, power, supply, and control.
- 1 Set of rheostats.
- 1 Vertical frame with 36 spaces on two tiers.
- 1 Set of accessories.
- Manual.

70 /



Instrumentation modules

Module "AMMETER 281": 0.5-2.5-5 A. In AC/DC.
 Module "AMMETER 282": 5-10-25 A. In AC/DC.
 Module "VOLTMETER-281": 100-250-500 V. In AC/DC.
 Module "VOLTMETER-281Q": 1kW 220 V/5 A.



Supply training modules

Module "ALI-24": 24V power supply.
 Module "CNM-281": 3-way switch/3 positions.
 Module "SIN-281": synchronism light.
 Module "REC-281": 200 Vdc rectifier. / 10 A.
 Module "CON-281": condenser.

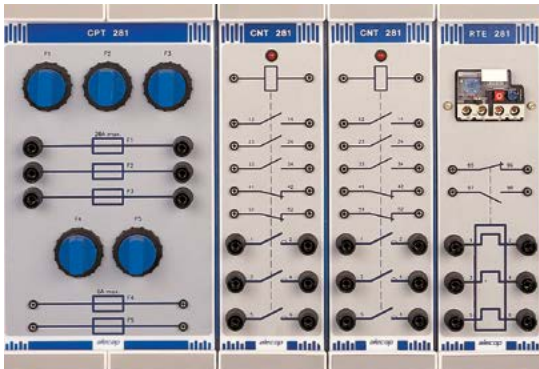

Power modules

Module "CPT-281": fuse protection circuit 6 and 20 A.

Module "CNT-281": energy meter.

Module "RTE-281": thermal relay.

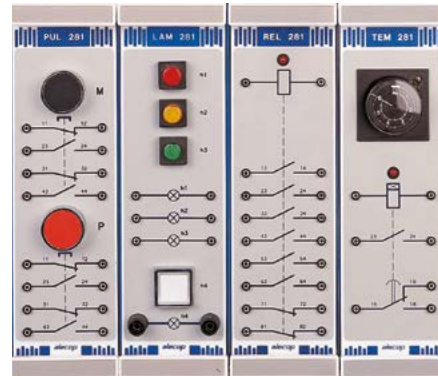

Control modules

Module "PUL-281": 2 buttons.

Module "LAM-281": 4 different coloured lamps.

Module "REL-281": manoeuvre relay with auxiliary contacts.

Module "TEM-281": timed from 0 to 60 sec.

Rheostats

Set of resistive loads equipped with 4 mm safety terminals for a fast connection to electrical machines under study. The electrical parts are protected from shock by electrically insulated metal casing.



RHEOSTATS	DC START-UP	EXCITATION	THREE-PHASE LOAD	THREE-PHASE START-UP
0.5 HP MODELS.	150/500	1500/250	3250	347
References	9EQR150500	9EQR1K5250	9EQR325000	9EQRTR3470
FEATURES	150 ohm. 500W. 1.83 A.	1,500 ohm. 250W 0.41 A.	3 x 470 ohm. 3 x 250 W. 3 x 1.45 A.	3 x 47 ohm. 3 x 300 W. 3 x 2.4 A.

Automation

Mains voltage electric automatisms MT-332

Teaching equipment for the study of different types of operations with single and three phase electric motors. Allows electric automatism practices and exercises to be carried out: commissioning and typical operation, interlocks, rotation inversions, protection, etc. They also allow the simulation and testing of any type of automation.

72 /

Electrical automation equipment

The equipment comprises:

- 1 desktop frame.
- 1 modular set of elements: protection modules and control and signalling modules.
- 1 set of accessories: operating practices, safety plugs, fuses, spare parts, etc.

Ref: 9EQMT332SE

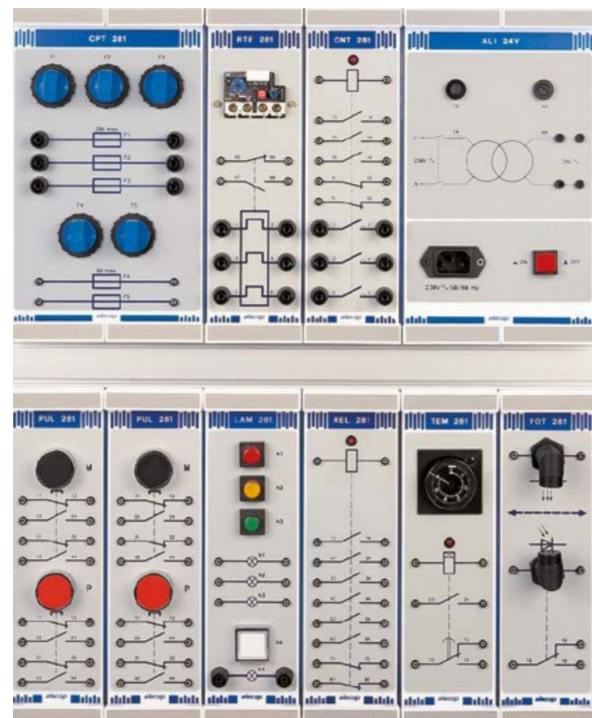

Educational Transformers

For the study and interconnection of different types of three-phase and single-phase transformers.

They have the following general characteristics:

- E-shaped or U-shaped oriented grain magnetic core.
- Set of standard coils for the 127/220 V.
- Safety terminals.



73 /

REFERENCES	MODEL	NAME-FEATURES
9EQTM1K596	TM-1K5	1.5 KVA single-phase transformer
9EQTT1K496	TT-1K4	1.4 KVA three-phase transformer

Three-phase autotransformer AT-3822

Three-phase functional autotransformer 1 KVA 380 - 220 V. Output available in safety terminal and power socket to feed an machines. Pilot lights indicating the presence of phases. Protection of phase using fuse.

Ref: 9EQAT38221



KMQ-120

Kit of rotary electric machines



Fast assembly kits and testing of electric machinery at low tension.

This equipment is meant for the study of the constitutive parts and fundamentals of the functioning of the most common rotary electric machines.

In an easy way and with a reduced amount of parts, the following types of machines can be studied:

- Independent excitation generator.
- DC serial generator.
- DC shunt generator.
- Independent excitation motor.
- DC serial motor.
- DC shunt motor.
- Three-phase asynchronous alternator.
- Three-phase synchronous motor.
- Single-phase motor.
- Universal motor.
- Single-phase induction motor.
- Repulsion motor.
- Wound-rotor three-phase motor.
- Squirrel cage three-phase motor.
- Dahlander motor.

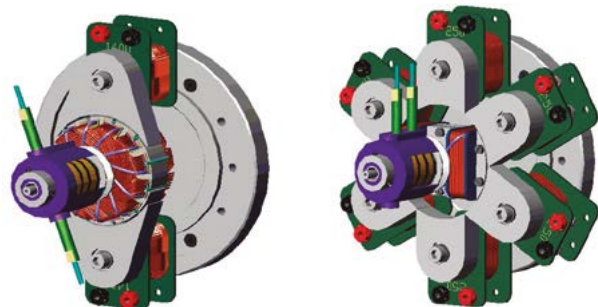

This equipment consists in:



Panel

This can be placed on the work surface or on a vertical frame. The support disc is attached to the panel, being used for screwing on the various field poles. The shaft protrudes from the centre of the disc and this is where the different rotors are attached.

An area has been set aside on the upper left-hand corner of the panel for the attachment of a drive motor that will allow experiments to be conducted with generators or provide a braking torque for the motors.

The right-hand side of the panel has the area for electric connections, using interchangeable labels. These allow the quick and clear interconnection of the various windings on the rotary machine subject to the experiment, providing the necessary information for its assembly. The areas the label is subdivided into make it easy to distinguish the electric connections both inside and outside the machine (connection board), without losing the perspective of a real machine.

The panel includes a 0-10 Vdc/2 A adjustable power supply for the excitation of the machines, as well as a tachometer for measuring the motor's velocity during the different types of tests.

Suitcase

It includes a series of parts (rotors, brush holders, windings, polar parts, etc), which allow configuring different rotary machines on a panel in a fast and easy way. The parts are the following:

- 1 Two-pole rotor.
- 1 Three-pole rotor.
- 1 Twelve-pole rotor.
- 1 Squirrel cage rotor.
- 1 Shaft.
- 6 Narrow field poles.
- 3 Wide field poles.
- 6 Windings of 240 turns.
- 4 Windings of 1,400 turns.
- 5 Brushes.
- 1 Brush holder.
- 6 Light poles.
- 1 Drive motor with belts.
- Tools and screws.

Power supply

The machines built are powered by a low voltage supply - 22/38 V AC/DC -, which ensures the students' safety. Hence, there are available (depending on choice) a TRI-120 transformer or a GTT-120 three-phase generator.

Standard accessories included:

- Practical and user's manual.
- Connexion wires.

Necessary accessories not included:

- Three-phase generator GTT-120, or as an alternative:
- Three-phase transformer TRI-120 + power supply 0-15 Vdc/5 A.

KMQ-100

BASIC kit of rotary electric machines

This is a “reduced” version of the dissectible machine, designed as a student work station.



76 /

Although it has fewer options than the full kit, it may be a valid option, depending on the nature of the practical activities to be held. Basically, the differences are as follows:

The assembly panel is smaller and can only be placed on the tabletop. It does not include the drive motor, tachometer, power source or connexions area neither. In this way, the result is a compact assembly panel.

The set of machinery construction, which is more reduced, fits in a suitcase that contains the following:

- 6 Windings of 250 turns.
- 2 Windings of 1,400 turns.
- 1 Twelve-pole rotor.
- 1 Squirrel cage rotor.
- 1 Brush holder.
- 5 Brushes.
- 2 Wide field poles.
- 6 Narrow field poles.
- 1 assembly support base.
- 1 assembly shaft.

The following machine models can be built and studied with this version:

- DC shunt motor.
- DC serial motor.
- Universal motor.
- Repulsion motor.
- Three-phase asynchronous elemental motor.
- Squirrel cage three-phase motor.
- Dahlander motor.

Standard accessories included:

- Practical and user's manual.
- Connexion wires.

Necessary accessories not included:

- Three-phase generator GTT-120, or as an alternative:
- Three-phase transformer TRI-120 + power supply 0-15 Vdc/5 A.

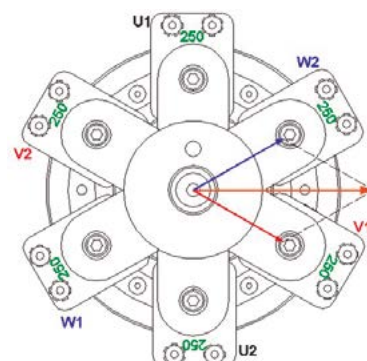

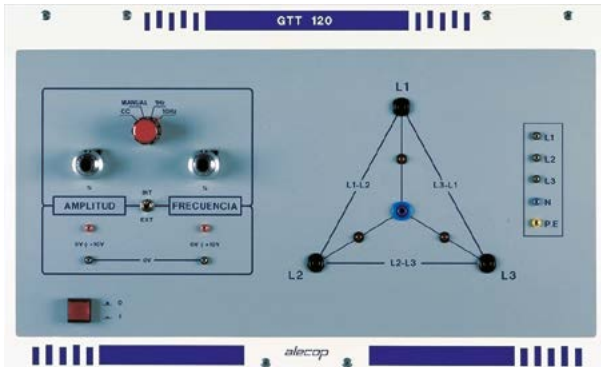

Three-phase generator GTT-120

This panel, which is mounted either on the frame or tabletop, incorporates a low voltage variable frequency three-phase generator with a single-phase mains supply of 110-230 V / 50-60 Hz (depending on the module). It has the following specifications:

- Phase-neutral voltage: 0-22 V variable strength adjusted by a potentiometer control.
- Phase-Phase: 0-38 V strength.
- Maximum current per phase: 5 A.
- Protection against current surges and short circuits.
- Frequency variation: 1-100 Hz in two scales and potentiometer control.
- Instant value output from the three-phase network, variable between 0-360°.
- 3 simultaneously variable 0-30 V / 5 A DC outputs
- Option of independent control of the value of the amplitude and frequency.
- User's manual.



Three-phase transformer TRI-120

This is a three-phase transformer which, depending on the model (TRI-122 or TRI-123), has a transformation ratio of either 220V to 22/38V or 380V to 22V-38V.

- Apparent power of 300 VA.
- The output voltage is 22V between phases (12.7V neutral phase) and 4 Amperes or 38V between phases (22V neutral phase) and 3.75 Amperes which can be selected by means of a commutator on the front template.
- 4 and 2 mm simultaneous output sockets.
- Over-current and short-circuit output protection with phase light indicators.
- The outputs are thermally insulated, with the resetting being produced automatically after the protective elements have been cold for a period of time.
- The frontal light display shows the order of phases (L1-L2-L3 or L1-L3-L2).
- The transformer's primary is protected by 2A fuses with a light indication if any should blow (pilot light out).
- User's manual.

TRAINING SUPPORT MATERIAL

User's manuals.

Their content includes the use, maintenance and safety norms, as well as the description of the parts and characteristics of the equipment.

Practical manuals.

This is a proposal of different activities that can be carried out, with the list of the necessary components, assembly and wiring instructions and the solutions for the teacher.

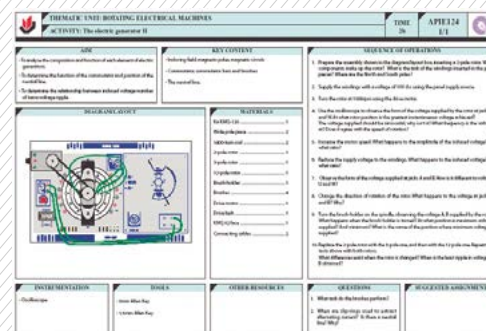

Machines

AC & DC Electrical machines

The machines are designed to work under safety standards, and can work coupled with other machines or independently.

To prevent user access to moving parts, the machine has built-in protectors in both axis outputs. The handling of the protectors is defined in the manual of each machine. They also incorporate a printed terminal block with safety terminals.

All electric machines are mounted on an aluminium bench with hooks at their ends so they can be quickly and easily fitted together without tools.

- The system is compatible with BNC-199 bench.
- Machines are available for 50 and 60 Hz.

78 /



AC electrical machines

MODEL	NAME-FEATURES	REFERENCE
AL-806	Universal electrical machine 370 W.	(50 Hz) 9MAK08064C (60 Hz) 9MAK08065C
AL-106	Single-phase asynchronous motor. Permanent capacitor 370 W.	(50 Hz) 9MAK01064C (60 Hz) 9MAK01065C
AL-206	Dahlander three-phase 2-speed asynchronous motor (Constant torque) 370 W.	(50 Hz) 9MAK0206AC (60 Hz) 9MAK0206BC
AL-306	370 W. Three-phase asynchronous motor rotor winding.	(50 Hz) 9MAK0306GC (60 Hz) 9MAK0306HC
AL-406	Synchronous rotor winding machine 370 W.	(50 Hz) 9MAK0406GC (60 Hz) 9MAK0406HC
AL-1106	Asynchronous three-phase squirrel cage motor 370 W.	(50 Hz) 9MAK1106GC (60 Hz) 9MAK1106HC

DC electrical machines

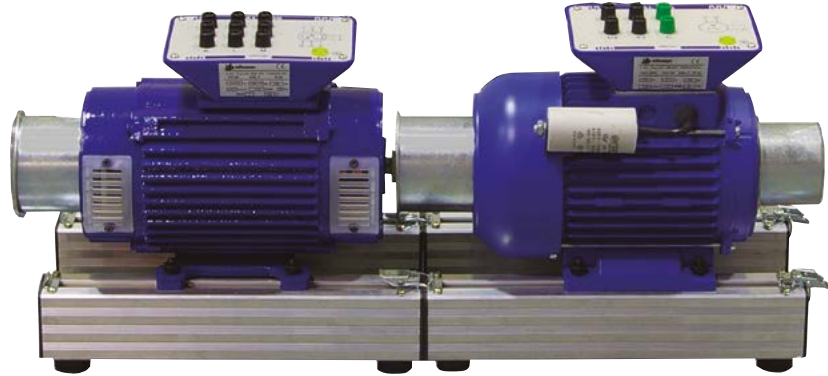

MODEL	NAME-FEATURES	REFERENCE
AL-506	DC educational independent excitation machine 0.5 HP	9MAK0506ZC
AL-606	DC educational excitation machine series 370W	9MAK0606ZC
AL-1006	DC educational excitation machine series Compound 0.5 HP	9MAK1006ZC

800 series

The ANG-800 and DIG-800 are complementary analog and digital training systems providing a reliable and cost-effective solution to teaching Electricity and Electronics.

Both systems are based on consoles into which pre-constructed circuit boards and components can be inserted to cover various aspects of analog and digital components and circuits. A prototyping area is included on the console to allow for extra experiments and project work to be undertaken.

The consoles not only offer a convenient and robust platform for conducting experiments but also provide all necessary power supplies and signal sources. When the preconstructed circuits are inserted into the console the relevant power supply connections are automatically made keeping unnecessary and potentially confusing connections to a minimum. The only additional equipment required is an Oscilloscope and a Multimeter. These trainers are supplied with comprehensive user guides and experimental procedures together with storage cases, connecting leads and components.

80 /

**ANG-800 console:
Analog electricity and
electronics**



**DIG-800 console:
Digital electronics**

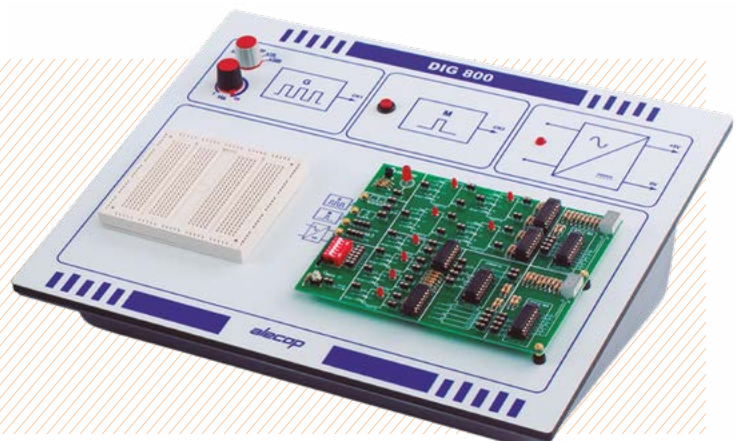

ANG-800 console: Analog electricity and electronics

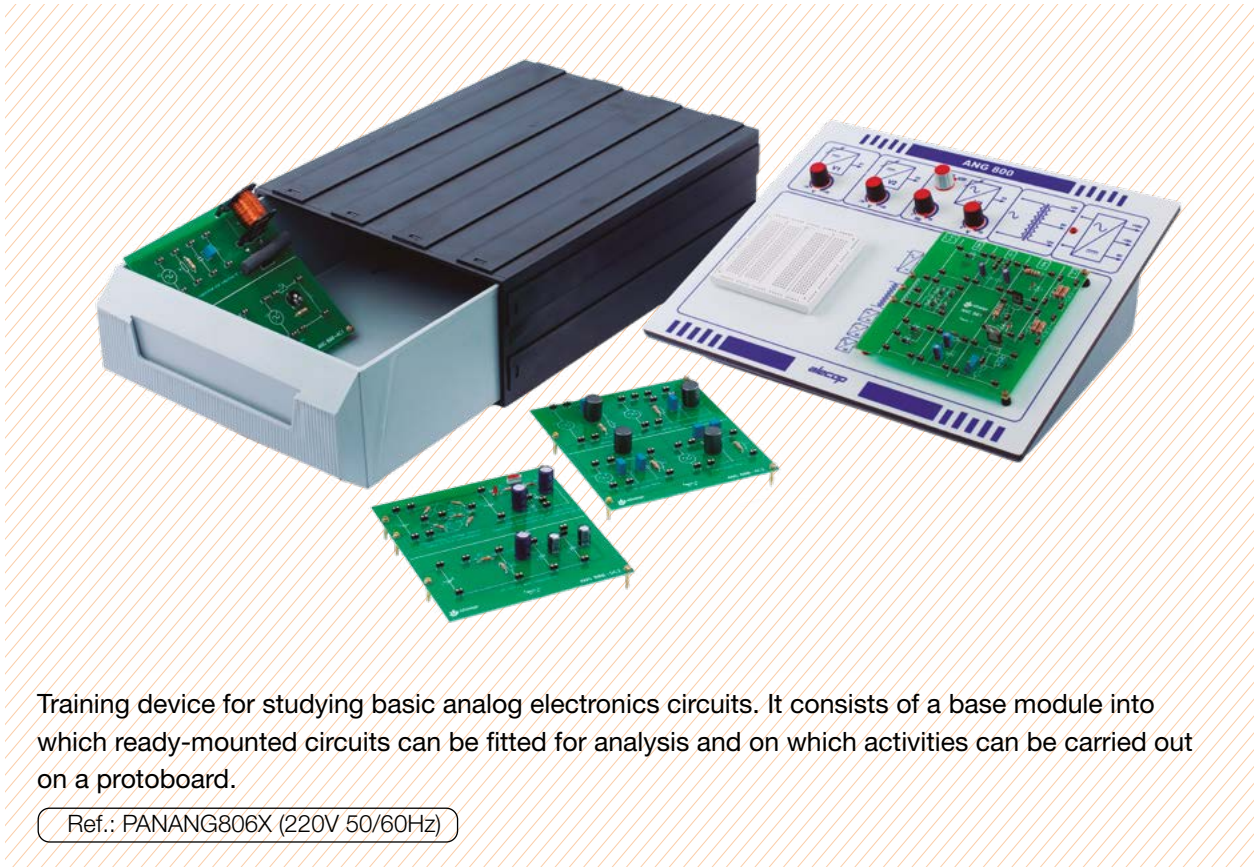

81 /

Training device for studying basic analog electronics circuits. It consists of a base module into which ready-mounted circuits can be fitted for analysis and on which activities can be carried out on a protoboard.

Ref.: PANANG806X (220V 50/60Hz)

Includes:

- Power source +/-15 volts dc 0.5A.
- Transformer with centre tapping 12-0-12 volts ac 0.3A.
- Two variable voltage sources +/-10 volts dc 0.1A.
- One AC voltage source with variable amplitude (0 - 10 volts) and frequency (1Hz to 1kHz).
- Protoboard.
- Storage drawer with connectors, accessories and electronic components.
- CD with: User Manual, Practical Manual and information about the main electronic components used on the device.

Complete with 5 sets of circuit boards:

- Set A: DC and AC circuits: (4 boards).
- Set B: introduction to Analog Electronics: (3 boards).
- Set C: analog Communications (3 boards).
- Set D: digital Communications (4 boards).
- Set E: fiber Optics trainer (1 board).

Set A: DC and AC circuits (4 boards)

Ref.: ACCANG800A

1. DC fundamentals and networks theorems I

- Basic DC circuit.
- OHM Law.
- Series circuit.
- Parallel circuit.
- Kirchoff's voltage law.
- Kirchoff's current law.
- Kirchoff's law combined.
- Thevenin circuits.
- Kirchoff with 2 sources.
- Superposition theorem.

2. DC fundamentals and networks theorems II

- Thevenizing a bridge circuit.
- Delta to star conversion.
- Charge and discharge of capacitors.
- Capacitors connected in parallel and series.
- Resolution of a DC circuit with capacitors.

3. AC Circuits I

- Sinusoidal waveform, AC values.
- Purely resistive AC circuit.
- Purely capacitive AC circuit.
- Purely inductive AC circuit.
- RC series AC circuits.
- RL series AC circuits.

4. AC Circuits II

- RLC series circuit.
- RLC series resonance.
- RC parallel circuit.
- RL parallel circuit.
- RLC parallel circuit.
- RLC parallel resonance.
- Low pass filter.
- High pass filter.

Set B: introduction to Analog Electronics (3 boards)

Ref.: ACCANG800B

1. ANG-801 Rectification and filtering

- Single phase half wave rectifier.
- Single phase full wave rectifier with intermediate centre tap.
- Single phase full wave bridge rectifier.
- Filtering.
- Parallel stabilizer.
- Serial stabilizer.
- Stabilized adjustable power supply.

2. ANG-802 Transistor circuits

- Polarization of the bipolar transistor.
- A Class power amplifier.
- AB Class power amplifier.
- The switching transistor
- Astable multivibrator.
- Monostable multivibrator.
- Bistable multivibrator.

3. ANG-803 Operational amplifiers

- Comparator without feedback.
- Variable gain inverting amplifier.
- Non inverting amplifier.
- Inverting amplifier.
- Subtractor.
- Power amplifier.

82 /

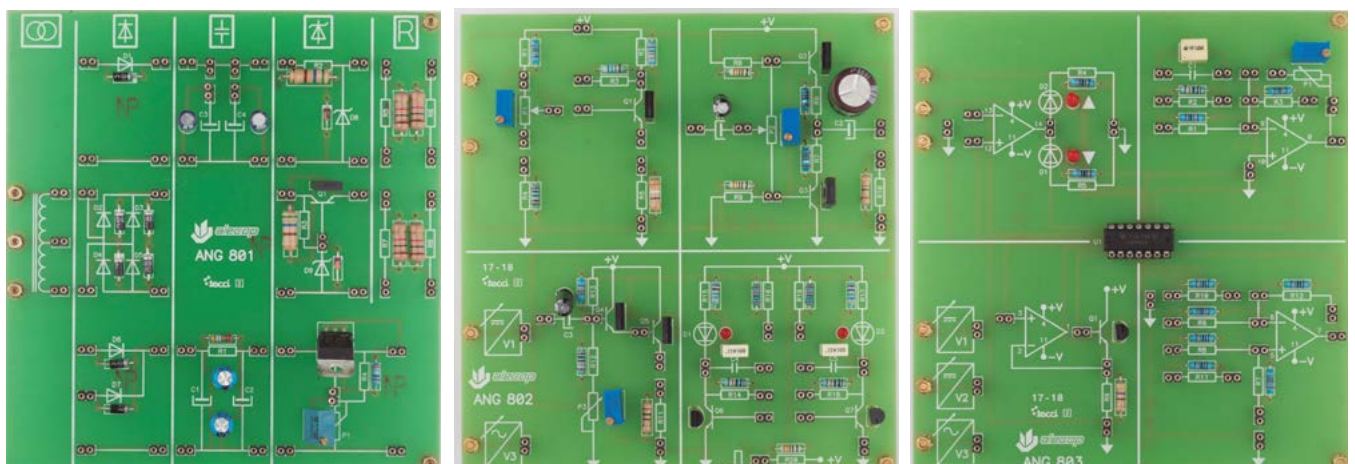

Set B boards.

Set C: analog communications (3 boards)

Ref.: ACCANG800C

1. ANG800-AM Amplitude Modulation

- AM double sideband (DSB) with full carrier.
- Measuring modulation depth.
- Double sideband with no carrier.
- Generation of single sideband (SSB) with a filter.
- Recognising different modulation types from oscilloscope patterns.
- Demonstration of spectral components i.e. two sidebands and a carrier.
- AM demodulation with an envelope diode detector.
- AM and DSB using a product detector.
- Single sideband demodulation with a product detector.
- Post detection filters.

2. ANG800-FM Frequency Modulation

- Generation of FM with a voltage controlled oscillator.
- Modulation Index, narrow and wideband FM.
- Recognising FM from its oscilloscope pattern.
- Slope detection of FM.
- Demodulation with a phase locked loop (PLL).
- Operation of a quadrature detector (used in most commercial FM radios).
- Operation and advantages of a limiter.
- Post detection filters.
- Pre-emphasis and de-emphasis.

3. ANG800-PM Phase Modulation

- Generation of PM with phase index from 0 to +/- 360 degrees.
- Recognising PM from its oscilloscope pattern.
- Relationship between phase and frequency modulation.
- PM detection using an FM demodulator and an integrator.
- Detection using a balanced mixer and carrier reference.
- Effect of phase modulation index on residual carrier amplitude.
- Carrier reference recovery using a PLL.

Set E: fiber optics trainer (1 board)

Ref.: ACCANG800E

1. ANG800-OPT Fiber optics

- LED optical source and driver.
- Fiber characteristics relative to wavelength and physical length.
- Estimation of light entry characteristics.
- Bandwidth and linearity.
- Estimation of bending and joint losses.
- Detectors and interface electronics.
- Compare Analog and Digital coding.
- Low frequency channel characteristics.
- PWM link implementation.

Set D: digital communications (4 boards)

Ref.: ACCANG800D

1. ANG800-BDE Baseband digital encoding

- Using a Pseudorandom Binary Sequence (PRBS) as a test bit-stream.
- Non Return to Zero (NRZ) unipolar and bipolar.
- Return to Zero (RZ) unipolar and bipolar.
- Alternate Mark Inversion (AMI) coding.
- Manchester coding.
- Identify coding systems from their oscilloscope patterns.
- Magnitude of dc component in different coding systems.
- Bit-rate clock recovery strategies.
- Word framing in bit-streams.

2. ANG800-ADK Advanced digital keying

- Generation of Binary PhaseShift Keying (BPSK), QPSK, 8-PSK, 16-APSK, 16-QAM with an IQ modulator.
- Symbol mapping into I and Q streams.
- Recognising different keying systems from their constellation diagrams.
- Relationship between bit-rate and symbol rate.
- Identify the effect of noise in a constellation diagram.
- Symbol space and error rate for different signal to noise ratios.
- Demodulation with an IQ demodulator.
- Carrier reference recovery with a Costas loop.

3. ANG800-DS Muestreo digital

- Pulse Code Modulation (PCM) using a 24 bit frame.
- 3 channel Time Division Multiplexing (TDM).
- Frame synchronisation and false syncing.
- Differential Phase Shift coding and decoding.
- Minimum shift keying, demodulation using phase demodulator.
- Gaussian minimum shift keying.

4. ANG800-PCM Pulse code modulation

- Signal sampling.
- A to D and D to A conversion.
- Resolution and number of bits.
- Signal reconstruction and aliasing.
- Pulse Width Modulation (PWM).
- Delta modulation and demodulation.
- Sigma Delta modulation and demodulation.
- Sigma delta modulator as an oversampling A/D converter.
- Conversion of a Sigma delta single bit-stream to N bit data.

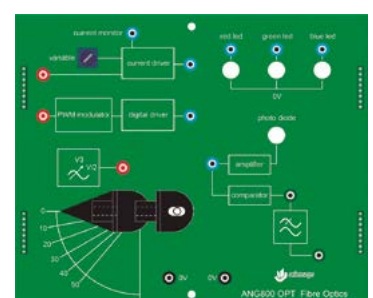
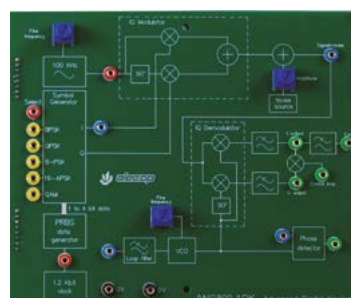

With the equipment, a set of practical activities is delivered on CD support. Given the open nature of the equipment, this set of activities can be complemented with other activities that the teacher considers appropriate. These can be carried out either on the Proto-Board or by designing new application circuits in the center's own laboratory.



84 /

ANG-800 activity example

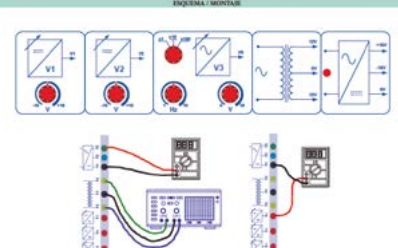
UNIDAD TEMÁTICA: PUESTA EN MARCHA DEL EQUIPO		TIEMPO	APCL800
ACTIVIDAD: Comparación de las fuentes de señal del panel		30'	2/2
ESQUEMA / MONTAJE 		MATERIALES Estimador de Señales Analógica ANG-800 Cables de conexión	
INSTRUMENTACIÓN Osciloscopio de doble traza Resistores	herramientas	OTROS RECURSOS	

DIG-800 activity example

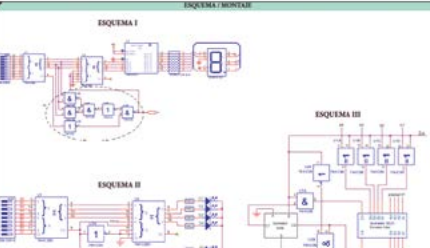
UNIDAD TEMÁTICA: CIRCUITOS COMBINACIONALES INTEGRADOS (MSI)		TIEMPO	APCL668
ACTIVIDAD: Claveador combinacional en BCD		30'	2/3
ESQUEMA / MONTAJE 		MATERIALES Estimador de Señales en Digital DIG-800 Tablero de conexión DCL-400 Circuito integrado 74HC285 Convertidor hexadecimal de 8 bits en código BCD Circuito integrado 74HC111 (Decodificador BCD a 4 segmentos) Circuito integrado 74HC26 Puertas NAND de dos entradas Circuito integrado 74HC24 (Señal inversora) Circuito integrado 74HC148 Puertas AND de tres entradas Circuito integrado 74HC10 Puertas NAND de tres entradas Circuito integrado 74HC12 (Puertas OR de dos entradas) Circuito integrado 74HC13 (Puertas OR octales)	
INSTRUMENTACIÓN Osciloscopio	herramientas Alfileres de pines Extractor de IC Pinzas y pinzas de desoldadura	OTROS RECURSOS Datosheet	

DIG-800 console: Digital electronics

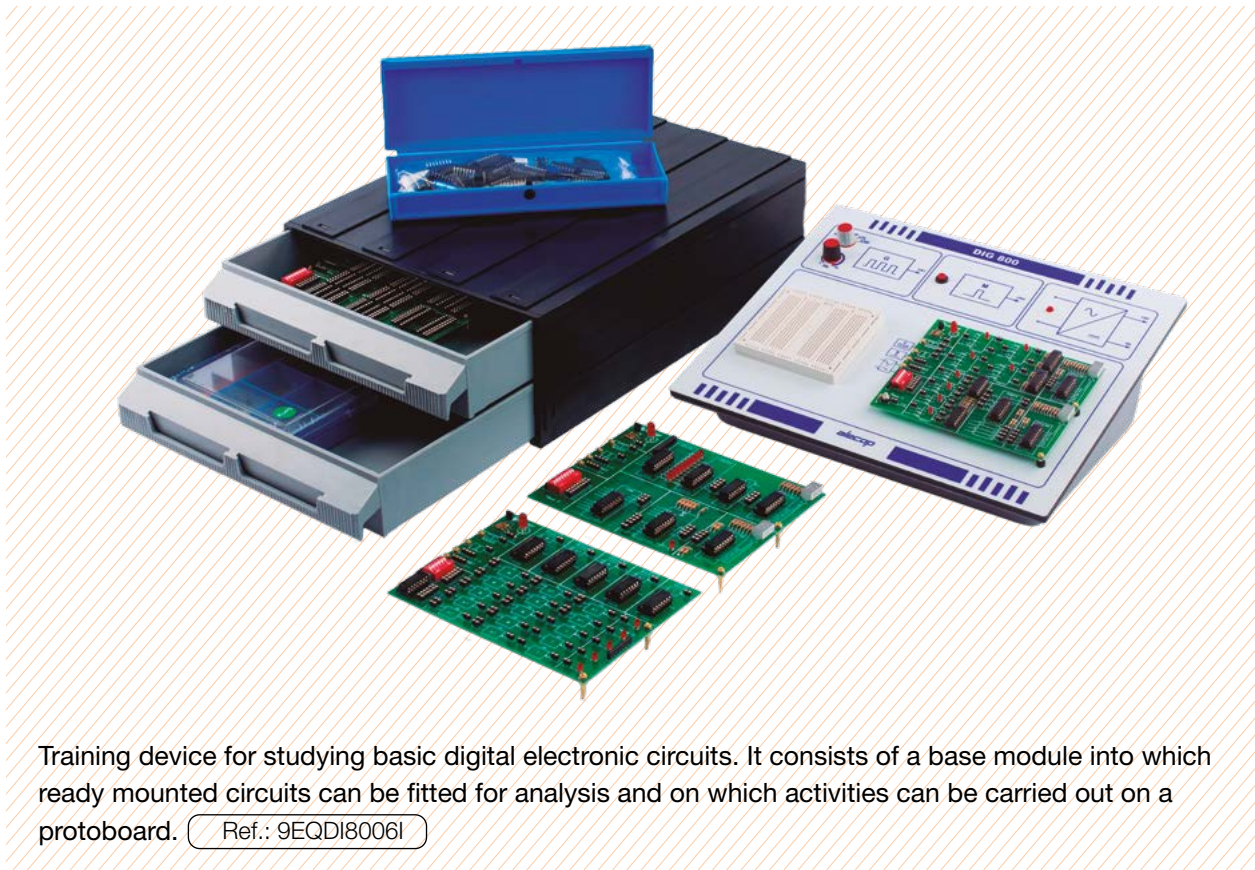

85 /

Training device for studying basic digital electronic circuits. It consists of a base module into which ready mounted circuits can be fitted for analysis and on which activities can be carried out on a protoboard. (Ref.: 9EQDI8006I)

Includes:

- Power source +5 volts DC 1A.
- Variable frequency oscillator, 1Hz - 100KHz (0-5V TTL).
- Digital pulse generator via push-button with debouncing circuit.
- Protoboard.
- Storage drawer with connectors, accessories and electronic components.
- CD with User Manual, Practical Manual and information on the main electronic components used on the device.

Complete with 4 applications boards:

- Gate and Logic functions.
- Combinational Circuit applications.
- Sequential Circuits.
- Digital Circuit construction board including 8 x 16 pin DIP sockets, 8 micro switches, 10 LED red diodes and four 7 segment displays.

Topic coverage includes:

- Knowledge of an IC.
- Light Emitting Diodes (LED).
- Study of the different logic gates (NOT, AND, OR, NAND, NOR, XOR, XNOR).
- Combinational circuits SSI.
- Priority encoders.
- Decoders and demultiplexers.
- Seven-segment Displays.
- Decoders BCD to Seven-segment Display.
- Multiplexors.
- Comparators.
- Arithmetic circuits in natural binary.
- Arithmetic circuits in BCD.
- Asynchronous flip-flops.
- Synchronous flip-flops.

The trainer system for power electronics takes the form of a modular programme for study through analysis of the four types of power converters used in industrial applications (rectifiers, choppers, inverters/undulators and AC regulators) and the power devices forming the basis for the design of these applications.

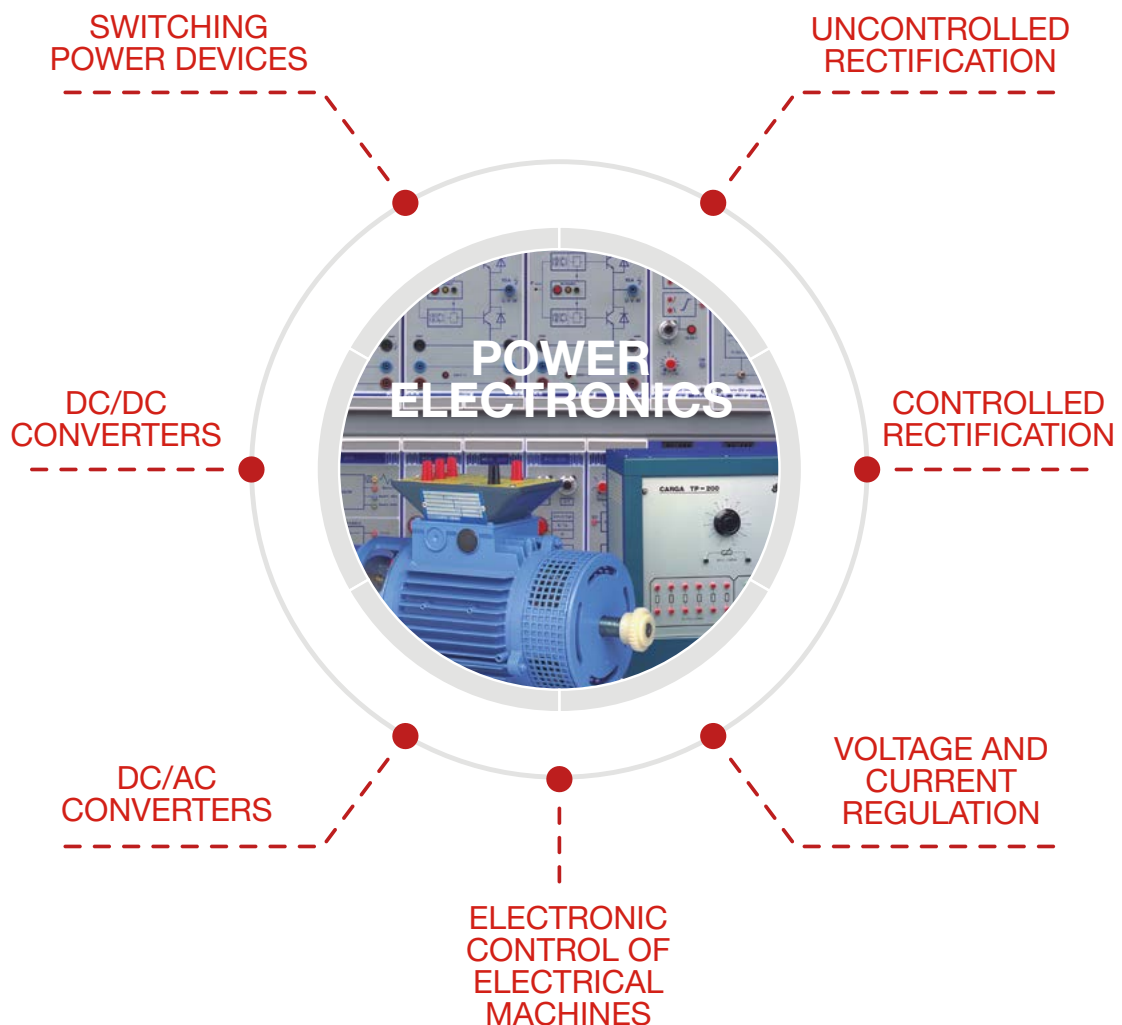

86 /

Safety

Safety connections at voltage points exceeding 30 V (connectors and sockets).

Quality

Compliant with the European low voltage and electromagnetic compatibility directives. Elements stamped in accordance with the IEC (Electrotechnical Commission) standard.



MODULAR PROGRAMME

The system is based on a “module” support, which can be configured and set up in a frame according to user needs. The frame has its benefits: **Less wires and less wasted time.**

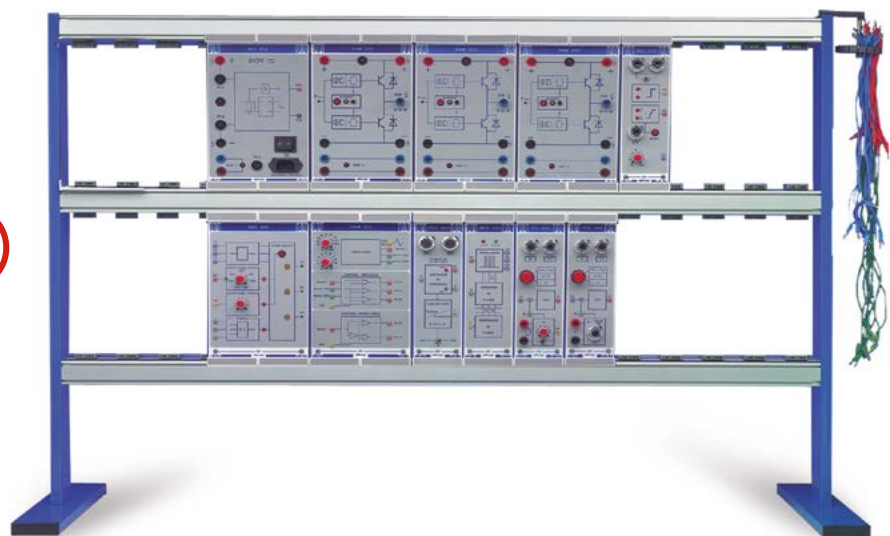
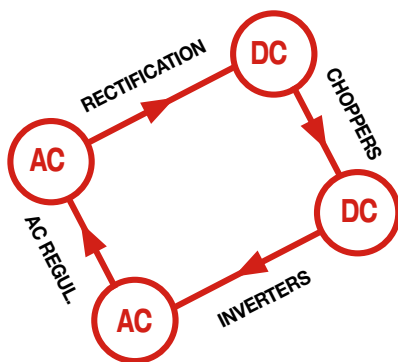

87 /

Back-up resources

This equipment includes a set of back-up elements to aid the trainer, e.g.:

- Training Guide, or trainer's class work guide, which defines goals, activities, sequencing, etc. and proposes a course outline. The activities and use of the different available resources (training devices, instruments, etc.) are structured on the basis of this guide.
- Practical Manual, which contains a series of units describing goals, teaching sequence, materials required, assessment criteria, etc.
- User Manual, with a technical description and information on the equipment.
- Theory Manual.



EP1/EP2

Controlled and uncontrolled rectification

Equipment for studying uncontrolled rectification (EP1), controlled rectification and alternating current regulation (EP2). It can be used at either low voltage (22/38 VAC, with CIR-120 and CRC-120 charges) or mains voltage.

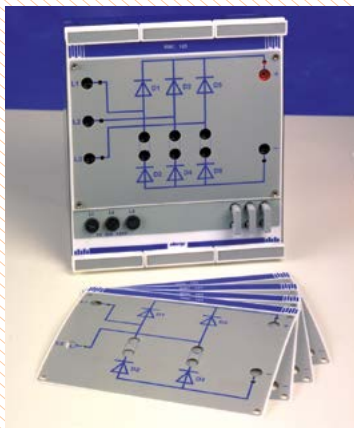

Uncontrolled rectification RNC-120

Ref: MDULRNC120

It enables the study of power diode-based rectifiers and their applications: single-phase, two-phase and three-phase half wave and full wave rectifiers.

- Based on the multi-panel concept.
- Includes the base module and five panels for study of the different bridges.
- Operating range: 22 VAC - 380 VAC.
- Safety connections and over-voltage and overload protection.

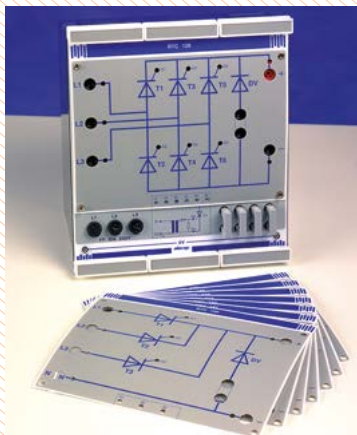

Controlled rectification RTC-120

Ref: MDULRTC120

It enables the study of power thyristor based controlled rectifiers and their applications: semi-controlled and fully controlled single-phase, two-phase and three-phase half wave and full wave rectifiers.

- Based on the multi-panel concept.
- Includes the base module and eight panels for study of the different bridges.
- Operating range: 22 VAC - 380 VAC.
- Safety connections and over-voltage and overload protection.

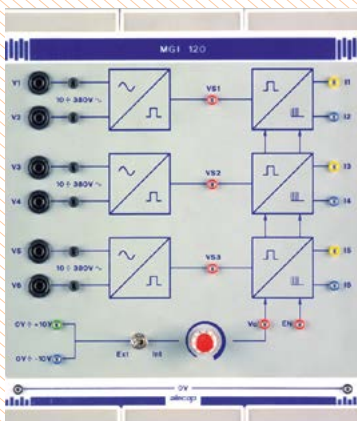

Pulse generator MGI-120

Ref: MDULMGI120

Sync and pulse train generator for ignition of the RTC-120 module thyristors.

- Control of up to 6 thyristors in three-phase bridge configuration.
- Three separate sync inputs, 10 – 380 VAC.
- Six pulse outputs, simultaneous and electrically insulated in pairs.
- Time-shifted pulse train according to external or internal set point.
- Input terminal for enabling/inhibiting pulse outputs.
- Requires ALI-700 ± 15 V power supply module and table-mounted frame.

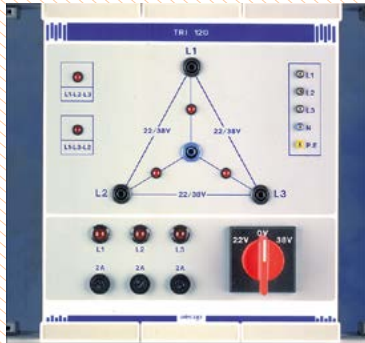

Three-phase transformer 220/380-22/38 Vac TRI-120

Ref: MDULTRI120

Phase transformer, depending on the model has a ratio of 220 V. to 22/38 V. or 380 V. a 22/38 V, with an apparent power of 300 VA. It is required for obtaining a low-power three-phase system, supplying the RNC/RTC-120 modules.

- Selection of 22/38 V output voltage by selector switch.
- Successive phase indicator light.
- Overload and over-voltage protection.
- Requires ALI-700 ± 15 V power supply module and table-mounted frame.

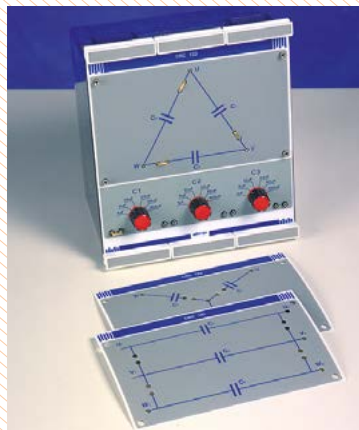

Resistive-inductive charge CIR-120

Ref: MDULCIR120

Charge module for low-power rectifier bridge work.

- Multi-panel system.
- Twelve panels for configuring different charge connection types.
- Charges: Y/A, R, L, R-L, free connection, etc., up to 50 Vef.
- Self-powered fan.



Rechargeable battery BAT-120

Ref: MDULBAT120

Module for simulating counter-electromotive force (DC motor), with single-phase 230 VAC mains supply. Charging circuit 12 V/6.5 Ah.

Resistive-capacitive charges CRC-120

Ref: MDULCRC120

Charge module for low-power rectifier bridge work.

- Multi-panel system.
- Three panels for configuring different types of charge connection.
- Charges: Y/A, free connection, etc., up to 63 Vef.

EP3

Switching power devices

Set of modules enabling practical analysis of the behaviour, advantages, disadvantages and problems of control of switching mode power devices.

Each module includes a block with the circuit's most significant voltage and current measurements, at reduced voltage and measured at the same point. The modules also include an electronic overcurrent and short-circuit protection system.

Bipolar transistor **TRS-200**

Ref: MDULTRS200

For studying the bipolar switching power transistor. It includes a PWM signal generator circuit for transistor control, which generates the input signal to the basic circuit (DRIVER), obtaining a 4 KHz rectangular signal with a variable duty cycle according to the user-accessible PWM potentiometer and Ton selector incorporated.

Equipped with a switching aid circuit via an anti-saturation diode.

IGBT **GTR-200**

Ref: MDULGTR200

Didactic module to study the switching behaviour of the IGBT (insulated gate bipolar transistor), included on the power IGBT module, as well as its control circuitry. To control the IGBT, a PWM signal generator is used which generates the input signal to the gate circuit (DRIVER), the latter is a rectangular 8 KHz. signal with a variable Ton of between 25 and 100 μ sec, depending on the accessible potentiometer.

MOSFET **MTF-200**

Ref: MDULMFT200

Didactic module to study the switching behaviour of the MOSFET power transistor, including a MOSFET module, as well as its control circuitry. To control the MOSFET, a PWM signal generator is used which generates the input signal to the gate circuit (DRIVER); the latter is a rectangular 10 KHz. signal with a variable Ton of between 25 and 80 μ sec, depending on the PWM potentiometer.

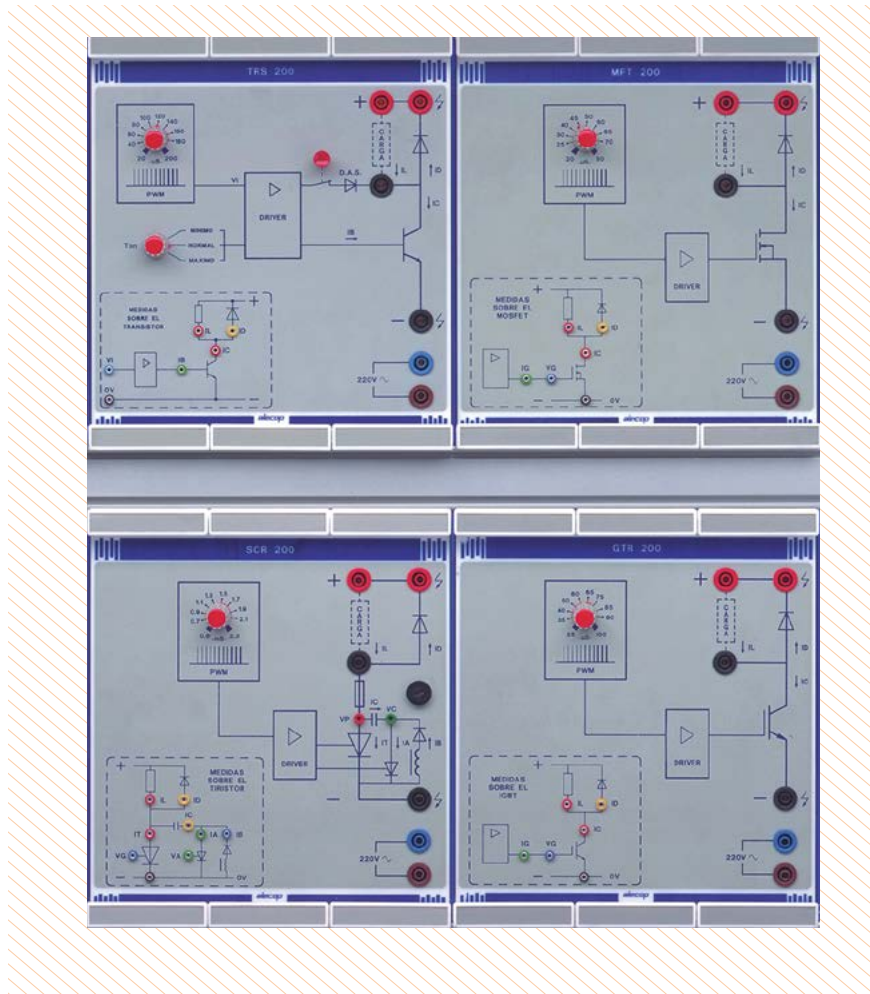

THYRISTOR

Ref: MDULSCR200

Didactic module to study the switching behaviour of the power thyristor, including a thyristor module, as well as its control circuitry. To control the thyristor, a PWM signal generator is used which generates the input signal to the gate circuit (DRIVER); the latter is a rectangular 350 Hz. signal with a variable T_{on} of between 0.6 and 2.3 μs c, depending on the PWM potentiometer.

The DRIVER block generates pulses for the power thyristor gate, as well as for the auxiliary thyristor of the integrated forced commutation circuit.

Elements REQUIRED:

- Table-mounted frame.
- ALI-700 supply module.
- ALI-200 supply module.
- TRF-200 transformer module.

EP4/EP5

DC/DC and DC/AC converters, choppers and inverters

A set of modules that can be configured differently for studying DC/DC and AC/DC converters (inverters or undulators), the various modulation techniques and their different applications such as the regulation and control of DC and AC motors, uninterruptable power systems, etc.

92 /

Continuous power bus **ALI-200**

Ref: MDULALI200

This didactic module contains a power supply of 310 V. continuous voltage, and can provide as far as a 10 A current. This is the constant direct voltage source for supplying the different converters, and it distributes the mains voltage to the other power modules.

It incorporates 10 A fuses on the alternate and continuous side, protecting the module against line surges and short circuits.

The module disposes of a voltage sampling on the continuous bus; this signal is used as a protection measurement against possible high voltages on the BUS.

Isolation transformer **TRF-200**

Ref: MDULTRF200

230/230 VAC transformer isolating the ALI-200 module network. It has primary and secondary protection by means of 10 A fuses.

Safety device centralisation **SEG-200**

Ref: MDULSEG200

This is a safety stage that must be included in all converters. It is a centralised protection block that protects the various converter circuits against bus overvoltage and overloads. It also adapts the control signals to be sent to the RAMA modules of the converter in question in both amplitude and impedance, to act on the transistor base drivers.

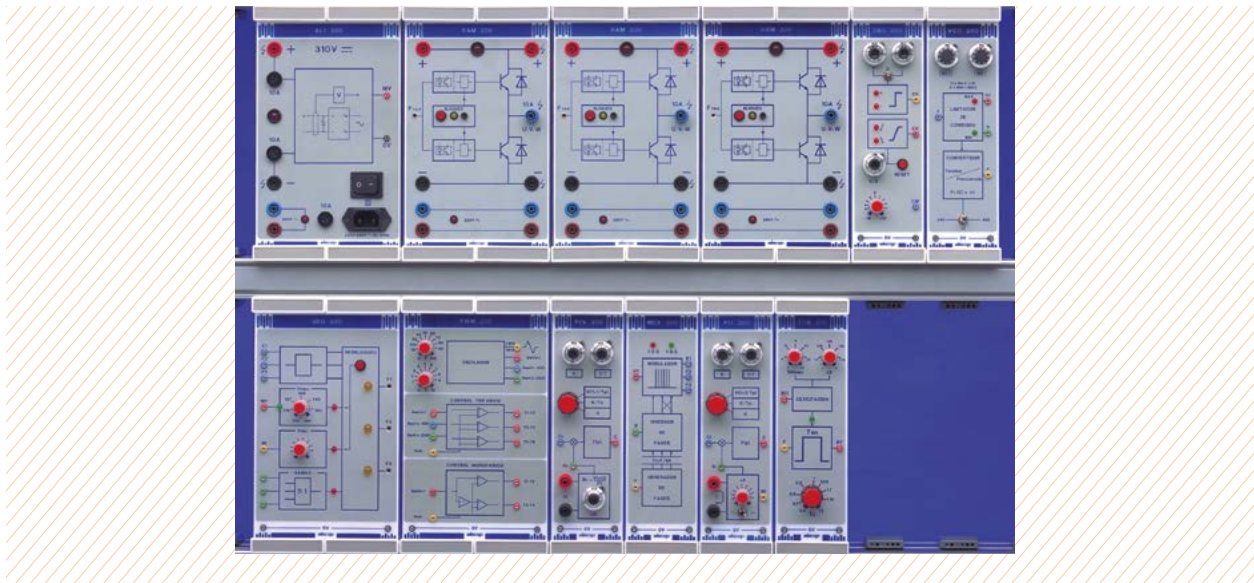

Branch of bipolar transistors **RAMA-200**

Ref: MDULRAM200

These modules allow configuring of the power blocks of any type of transistorised converter, each of them forming one of the branches of the converter. The number of modules to use depends on the type of circuit which will be implemented (two for DC/DC converters and three for DC/AC converters).

Each module includes two power transistors as well as base DRIVER circuits required for control purposes.

It includes a JACK-type connector where the control signals from the SEG-200 module are received. These signals are optocoupled allowing a complete separation of the circuits from the power circuits.

Inside the module, a logic processor has been integrated which is responsible for detecting any error in the RAM operation. If an error occurs, the processor blocks automatically and remains inoperative. The factors why the protection system lock the operation of the module are:

- Instantaneous intensity by transistors greater than 25 A with a longer duration than 4 msec.
- BUS voltage below 120 V.
- Network supply failure.
- Internal defects of circuit.

Elements **REQUIRED**:

- Table-mounted frame.
- ALI-700 supply module.
- ALI-200 supply module.
- TRF-200 transformer module.

Set point generator **SNG-200**

Ref: MDULSNG200

This module generates three types of control set points: step, ramp and a set point that can be varied manually through potentiometric control.

Voltage-frequency converter **VCO-200**

Ref: MDULVCO200

It converts the set point voltage applied at the input into a frequency using a voltage-controlled oscillator. It forms the control part of the transistorised inverter together with the TON-200 and MDX-200 modules, for asynchronous machine speed variation.



Ton driver **TON-200**

Ref: MDULTON200

The TON-200 module is in charge of the pulse width modulation coming from the voltage-frequency converter (VCO-200) for the control of the transistorised ondulator. It includes a pulse width adjustment circuit (Ton) and an overdrive circuit.

Generator-inverter-phase modulator **MDX-200**

Ref: MDULMDX200

This module generates the control signals to be applied to the six transistors that make up the inverter bridge. It has a phase generator, a phase inverter in accordance with the set point sign and a modulating circuit.

Pulse width modulator **PWM-200**

Ref: MDULPWM200

It generates pulse width-modulated signals, providing the control commands to the power converters. It includes an oscillator block, which generates a triangular voltage and three 120° out-of-phase sinusoidal voltages, a “three-phase control” unit, for control of three-phase inverters, and a “single-phase control” unit for the single-phase inverters.

94 /

EP6

Speed and current regulation accessories

A small set of two modules that can complement the sets of converters to enable study of closed loop speed regulation.



Current Loop PI Controller **PII-200**

Ref: MDULPII200

Equipped with a current sensor, based on a Hall-effect cell, with an incorporated adjustable gain conditioner and three possible user-selectable control actions (proportional, integral and proportional-integral).

Speed Loop PI Controller **PIV-200**

Ref: MDULPIV200

Provided with an adjustable gain conditioner circuit for tachometer, comparator of set point with feedback voltage, and three possible control operations (proportional, integral and proportional-integral).

Assembly and power supply system

Table-mounted training frame

This is a physical support for the modules, blocks and panels used for the practical activities. It transmits the electrical supply from the power supply modules to all the modules requiring it.

Ref.: 9EBxPxxCP

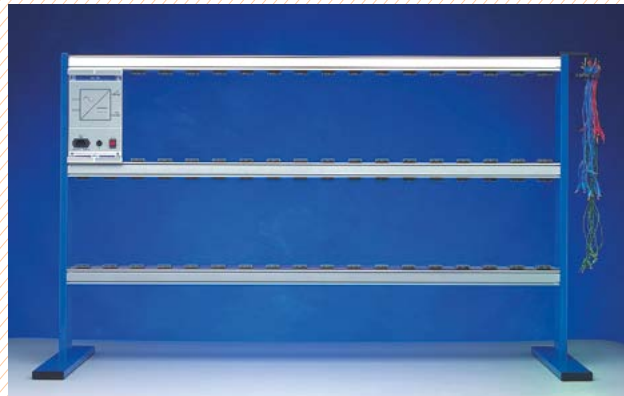

95 /

The assembly frame and the ALI-700 power supply module form the basis of the modular programme and are required for all training module configuration requiring an electronic power supply.

The frame dimensions are selected in accordance with the equipment to be mounted on the frame. Its horizontal structure consists of an aluminium section and the rectangular side supports are oven-dried painted iron sections.

As regards locating the frame on the work tables, it may be fixed (the frame can be fixed to the tables) or mobile (in which case it is supplied with removable legs with non-slip feet).

The module power supply and fixing systems consist of a series of connectors, into which the connection points located on the rear of the modules are inserted, exerting a slight pressure.

All the frame connectors are interwired in order to share a common voltage, guaranteeing a suitable power supply to the modules installed. The power is supplied via the ALI-700 module.

x: 1,2: frame height in tiers.

xx: 10, 14, 18, 20, 22, 28, 36, 44: n° of insertable single modules.

±15 V SUPPLY

Training module

A supply source of ± 15 V. The power supply is transmitted via the table-mounted frame, and these voltages are also available at 2 mm terminals.

It includes the corresponding pilot LEDs to indicate correct output functioning, providing a nominal current of 2 A. It includes thermal and short-circuit protection, with automatic reset after a few seconds.

Ref.: MDULALI700

Electronic control of electrical machines

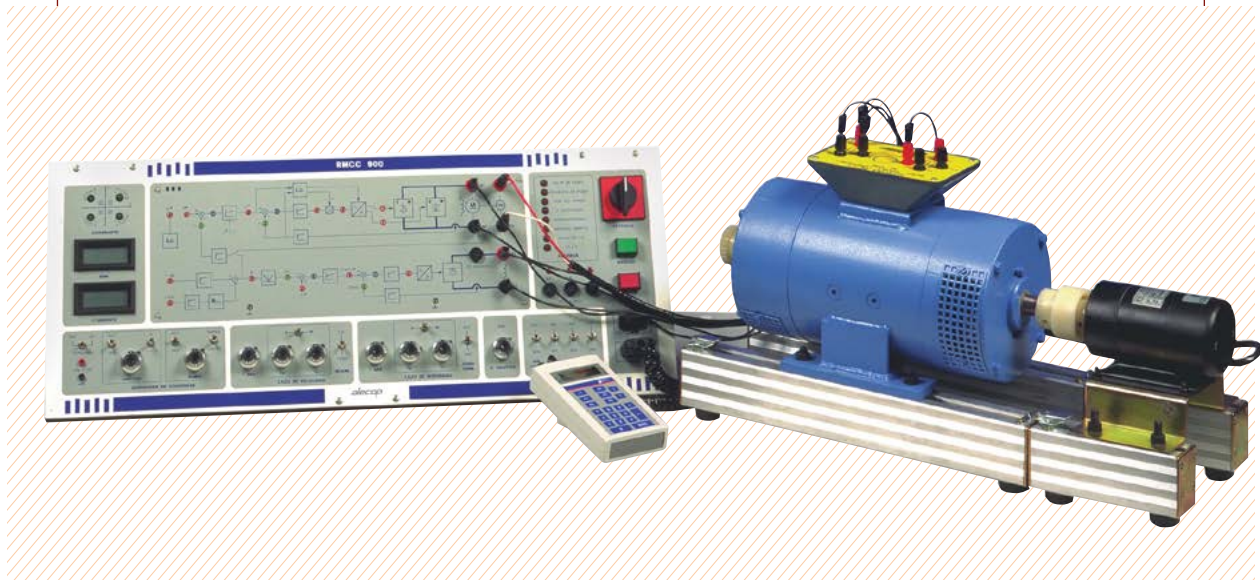

96 /

The electronic motor speed regulation training devices presented in this catalogue are the result of having converted the corresponding industrial regulators into training devices, reproducing their construction and operating principles while providing major educational and functional advantages.

Basic content that can be worked on using this equipment:

- Block diagram representation of control systems.
- Speed control in both rotation directions.
- Four-quadrant operation.
- Operation at constant torque and power.
- Current and speed regulation, types of feedback and correctors.
- Speed regulation, P and PI correctors.
- Torque and speed regulation. Feedback loops and correctors.
- Torque regulation: detection of rotor position and set point generation.
- Dissipative braking: crowbar circuit.
- Analytic corrector tuning in accordance with the symmetric optimum criterion.
- Adjustment and tuning techniques.
- Asynchronous motor speed variation. Voltage/frequency ratio.
- Failure diagnosis and repair.

ELECTROTECHNICAL POWER SYSTEMS

DC motor speed regulation

RMCC-900

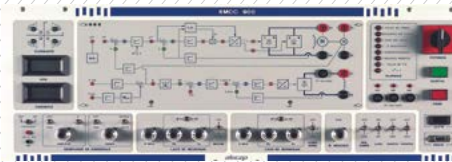

AC motor speed regulation

RMCA-900



Brushless motor speed regulation

RMBR-900



97 /

Functions

- Panel support, for use in either vertical position (frame) or table-mounted.
- Wireless equipment configuration.
- Power and control circuit symbols printed according to the IEC (International Electronic Commission) European standards.
- Test points in 2 mm sockets for control signal measurement.
- External set points may be worked with, to enable actuation from an automaton or other control element.
- Motor operating conditions (voltage, current, speed, etc.) can be viewed on a display on the panel, with no need for additional instruments.
- One single supply for all the equipment.

Failures

The training devices enable students to develop failure diagnosis and repair skills: they can analyse and diagnose the failures and repair them virtually.

Back-up resources

This equipment includes a set of back-up elements to aid the trainer, e.g.:

- User Manual, containing the instructions for start-up and operation of the equipment, its technical characteristics and detailed information on the failure repair system.
- Practical Manual, describing goals, teaching sequence and solutions for each of the practical activities.
- Theory Manual.

Safety

Both the control panels and the electrical machines have safety terminals at voltage points exceeding 30 V, in compliance with the European Low Voltage Directive.

RMCC-900 DC

Electronic speed regulation of DC SCR motors

Equipment designed for studying the functioning, adjustment and repair of the speed regulation systems of DC motors, based on double thyristor bridge technology, and the different associated control options.

The following basic content may be worked on:

- Block diagram representation of control systems.
- Current and speed regulation, types of feedback and correctors.
- Four-quadrant operation.
- Constant torque and power operation.
- Adjustment and tuning techniques.
- Failure diagnosis and repair.

98 /

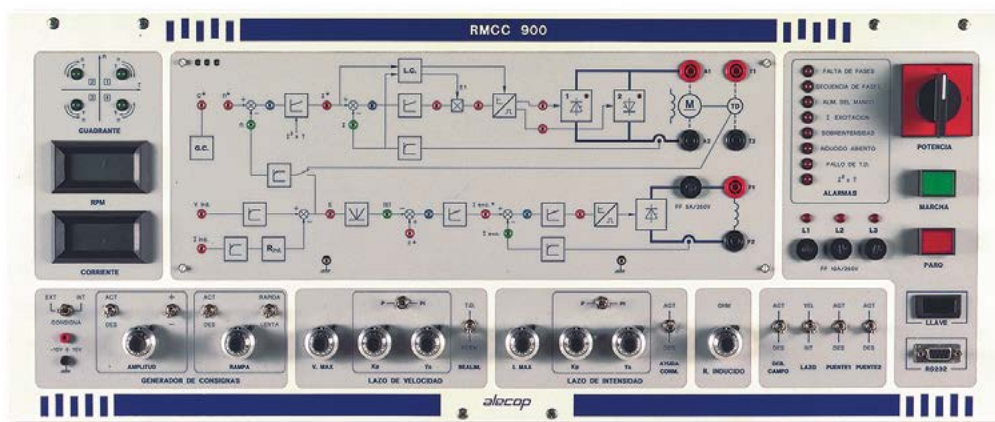

DC engine regulation unit RMCC-900

A multi-panel system which enables different types of controls to be set up. It has six panels, each with unit diagrams printed on it, which are automatically recognised by the equipment when they are fixed in place. This allows for the following setups:

- Torque regulator in a single quadrant.
- One-way speed regulator, with feedback via tachodynamo.
- Speed regulator with feedback via f.c.e.m.
- One-way speed regulator, with operation at a constant torque and power.
- Four quadrant torque regulation.
- Speed regulator in both spin directions, with regenerative braking. The board controls allow selection of the working mode of the controller and adjusting the system parameters.
- Slogans external, internal, manual, ramps, etc.
- Parameters of the different weightings.
- Limitations of current and speed.
- Etc.

The panel incorporates two LCD displays which enables the speed and current to be displayed, as well as indicator lights for the functioning quadrant of the motor.

The unit is equipped with a set of protection devices and alarms to facilitate analysis of any occurrence, guaranteeing total safety:

- Phase loss.
- Incorrect phase sequence.
- Control supply failure.
- Excitation current loss.
- Maximum current limitation.
- Open armature circuit.
- I² x t protection.

Accessories supplied:

- User's manual and practical activities.

NECESSARY elements which are not supplied:

- AL-506 or 1006 motor (page 104).
- Braking system (page 105).

Optional elements:

- Failure programming console (page 103).
- Theory Manual.
- Data collection and display system.
- 380-220 Triphasic autotransformer.

Technical characteristics

Reference: 9EQRMC900
Supply: Three-phase 230 V- 50/60 Hz
Armature output: 0 to 230 V- 3 A
Excitation output: 0 to 230 V- 0.6 A
Power: 0.6 kW
Regulation range at constant torque: 0 to 1,500 rpm
Regulation range at constant power: 0 to 3,000 rpm

Didactic transformer 380-220 triphasic AT-3822

An autotransformer for various applications in which it is necessary to have a 220 V triphasic voltage, with the following characteristics:

- Supply: triphasic 380 V - 50 Hz.
- Output: triphasic 220 V - 50 Hz.
- Power: 1 KVA.
- Output available as safety terminals and power points.
- Pilot lights indicating presence of phases.
- Fused protection in each phase.



RMCA-900 AC

Electronic speed regulation of alternating current motors

Equipment designed for studying the functioning, adjustment and repair of asynchronous motor speed regulation systems, based on frequency converter technology.

The following basic content may be worked on:

- Block diagram representation of control systems.
- Asynchronous motor speed variation. Voltage/frequency ratio.
- Dissipative braking: crowbar circuit.
- Speed control in both rotation directions: four-quadrant operation.
- Operation at constant torque and power.
- Adjustment and tuning techniques.
- Failure diagnosis and repair.

100 /

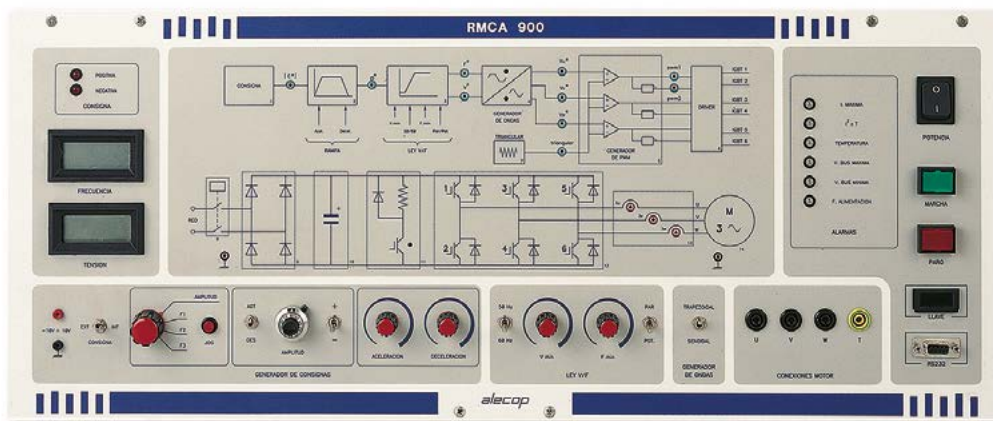

AC engine regulation unit **RMCA-900**

The panel incorporates a frequency converter designed to supply an asynchronous motor of up to 1 kW power. It consists of a triphasic inverter based on IGBTs and all of the circuitry necessary for their control.

It enables a triphasic output voltage, variable in amplitude and frequency, to be obtained, by means of the PWM modulation. The frequency may be increased to double the nominal frequency in the constant power mode, which enables a control to be obtained above and beyond the nominal speed of the motor. Sine or trapezoidal PWM modulation can be selected.

The controls incorporated enable the work mode of the converter to be selected, as well as the parameters of the system to be adjusted:

- External, internal, manual commands, ramps, etc.
- Parameters at constant torque and power.
- Low speed torque compensation.
- Etc.

The effective voltage and frequency may be displayed alternately on the panels LCD display, and additionally there are lights indicating the quadrant of the functioning of the motor and the activation of energy devolution system (braking).

The unit is equipped with a set of protection devices and alarms to facilitate analysis of any occurrence, guaranteeing total safety:

- Maximum current.
- Maximum temperature.
- Maximum bus voltage.
- Minimum bus voltage.
- Control supply failure.
- I² x t protection.

Accessories supplied:

- User's manual and practical activities.

NECESSARY elements which are not supplied:

- AL-1106/06 motor (page 104).
- Tachodynamo (page 105).
- Braking system (page 105).

Optional elements:

- Failure programming console (page 103).
- Theory Manual.
- Data collection and display system.

Technical characteristics

Reference: 9EQRMCA900

Supply: Single-phase 230 V- 50/60 Hz

Output voltage: Three-phase 0 to 220 V

Output frequency at constant torque: 0 to 50 Hz or 0 to 60 Hz

Regulation range at constant power: 0 to 100 Hz or 0 to 120 Hz

Power: 1 kW

RMBR-900

Electronic regulation of Brushless motor speed

Equipment designed for studying the functioning, adjustment and repair of AC brushless motor speed regulation.

The following basic content may be worked with:

- Block diagram representation of control systems.
- Torque regulation: detection of rotor position and set point generation.
- Speed regulation, P and PI correctors.
- Dissipative braking: the crowbar circuit.
- Adjustment and tuning techniques.
- Failure diagnosis and repair.

102 /

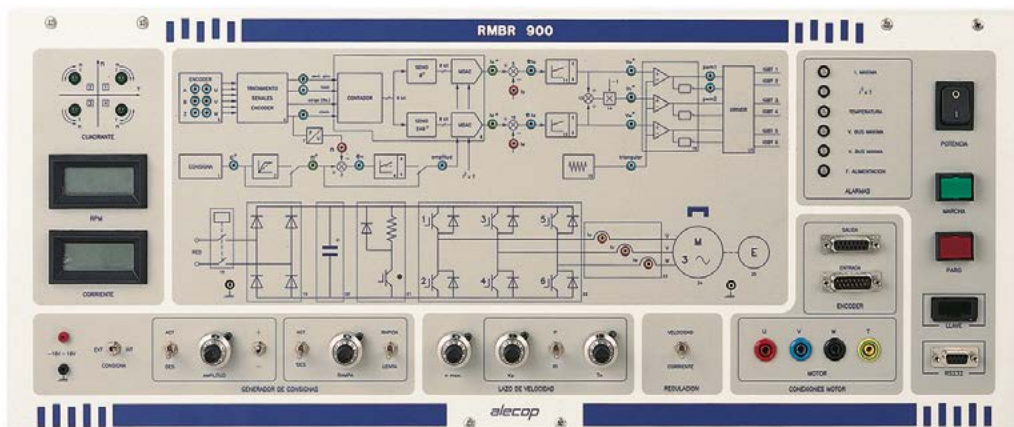

Brushless engine regulation unit **RMBR-900**

The power circuit is made up of a rectifier bridge, a filter condenser and a triphasic inverter based on IGBTs. In addition to this, it incorporates a crowbar circuit for protecting the equipment when the voltage in the bus increases through braking energy devolution.

The controls incorporated enable the function mode of the converter to be selected, in addition to enabling the parameters of the system to be adjusted:

- External, internal, manual commands, ramps, etc.
- Corrector parameters.
- Regulation in current or in speed.
- Limitation of maximum speed.

The speed and current may be displayed on the panel's LCD display, and additionally there are lights indicating the quadrant of the functioning of the motor and the activation of energy devolution system (braking).

The unit is equipped with a set of protection devices and alarms to facilitate analysis of any occurrence, guaranteeing total safety:

- Maximum current.
- Maximum temperature.
- Maximum bus voltage.
- Minimum bus voltage.
- Control supply failure.
- I² x t protection.

Accessories supplied:

- User's manual and practical activities.

NECESSARY elements which are not supplied:

- Brushless motor (page 105).
- Braking system (page 105).

Optional elements:

- Failure programming console (page 103).
- Data collection and display system.

Technical characteristics

Reference: 9EQRMBR900

Supply: Single-phase 230 V- 50/60 Hz

Output voltage: 0 to 196 V

Output frequency: 0 to 200 Hz

Power: 1 kW

Failure programming and repair system

The RMCC, RMCA and RMBR-900 regulation panels have a system for failure diagnosis and virtual repair, based on a micro processor in the panel which communicates with the user via a failure programming console with a 4 x 24 character LCD display and a 21-key membrane keyboard.

An electronic key, inserted in a slot in the panel, allows access to the trainer menu to change the codes that generate the failures.



UNIT	Nº OF FAILURES PROGRAMMABLE	Nº OF FAILURES PROGRAMMABLE
RMCC-900	31	Set point failures, tacho dynamo failures, thyristor triggering failures, etc.
RMCA-900	14	Set point failures, rotation reversal failures, crowbar failure, etc.
RMBR-900	26	Set point failures, corrector failure, failure in the encoder processing circuit, etc.

Electrical machines and braking systems

All the electrical machines are mounted on an aluminium bedplate, with their corresponding end connections for quick, easy coupling to other machines, brakes or tacho dynamos. They also include a printed terminal block with safety terminals and protection guards on the shafts.



DC motor **AL-506 / AL-1006**

Model AL-506 is an independent excitation motor. Model AL-1006 is an compound excitation machine.

Characteristics	AL-506	AL-1006
Reference	9MAK0506ZC	9MAK1006ZC
Power	370W	370W
Nominal voltage	220V	220V
Nominal speed	2500 rpm	2500 rpm
Shaft height	80	80



Three-phase asynchronous motor **AL-1106**

Single-speed three-phase asynchronous squirrel-cage motor (50Hz/60Hz).

Characteristics	AL-1106	AL-1106
Reference	9MAK1106GC	9MAK1106HC
Power	400W	400W
Nominal voltage	230/400V	230/400V
Nominal speed	1420 rpm	1690 rpm
Shaft height	80	80

104 /



Asynchronous motor **BRUSHLESS AC**

AC Servomotor, associated to the corresponding regulator, it behaves as a high prestaton's DC motor (high nominal speed, low inertia, small, etc.), without needing of brushes. It is composed by an inducted winding placed in the stator, permanent magnets in the rotor and solidary encoder.

Characteristics	AL-BRU80
Reference	MTRALBRU80
F.c.e.m.	150 V
Nominal intensity	4 A
Nominal torque	2.5 Nm
Maximum speed	4,000 rpm
Encoder	2,000 impulses/turn
Shaft height	80 mm

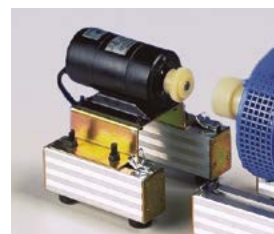

Tachogenerator **REO-444**

Characteristics	REO-444-80
Reference	9EQDINTQ80
Constant	60 V/1000 rpm
Maximum speed	10,000 rpm
Axis height	80 mm



FUNCTION. Drag motor and braking of machines for testing.

Braking system - bank

This machine can be easily coupled to the bedplate, in accordance with safety standards preventing bedplate malfunctioning.

The bedplate is controlled by potentiometric dials for torque and speed, or by means of external signals enabling it to be controlled by DAS and computer.

Constant display of power, speed and torque exerted on the bedplate axis, signals available at an external connector.

Technical characteristics

GENERAL

Supply:

Single-phase mains 190 – 250 VAC – 5.25 Amp.- 50/60Hz

Type of machines tested:

- Free-standing, heights 71, 80 and 90 mm.
- Heights 80 and 90 mm on Alecop sections.

Machine fixed for testing by elastic coupling.

FUNCTIONING AS A DRAG MOTOR

Speed: 0 to 2000 rpm

Rated: 800 W

Maximum torque: 9.7 Nm

FUNCTIONING AS A BRAKE

Maximum speed: 2450 rpm

Torque: 0 to 10 Nm

Rated: 800 W

Braking system by a d.c. generator FRE-506

Ref.: 9EQREF0437

Electrical machines braking system by means of a dc generator coupled to the shaft of the machine. The kit includes:

- 1 EXC-281 module. Variable output rectifier with autotransformer. Input 220 V ac, output: 0 – 220 V dc
- 1 Rheostat 150 Ohm / 500 W
- 1 DC generator independent excitation 370 W, AL-506. Nylon coupling.

4 mm safety sockets. Frame (optional) not included.

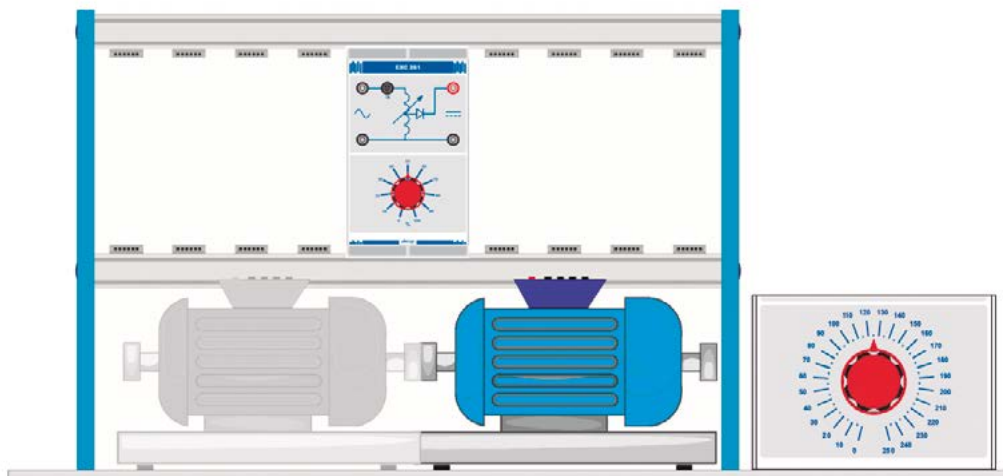

The training equipment designed for this area consists of a modular programme enabling study through the analysis and design of different measurement and regulation systems. Functional models with integrated industrial sensors are used to study both these sensors and closed loop regulation systems for different processes (speed, temperature and level).

106 /

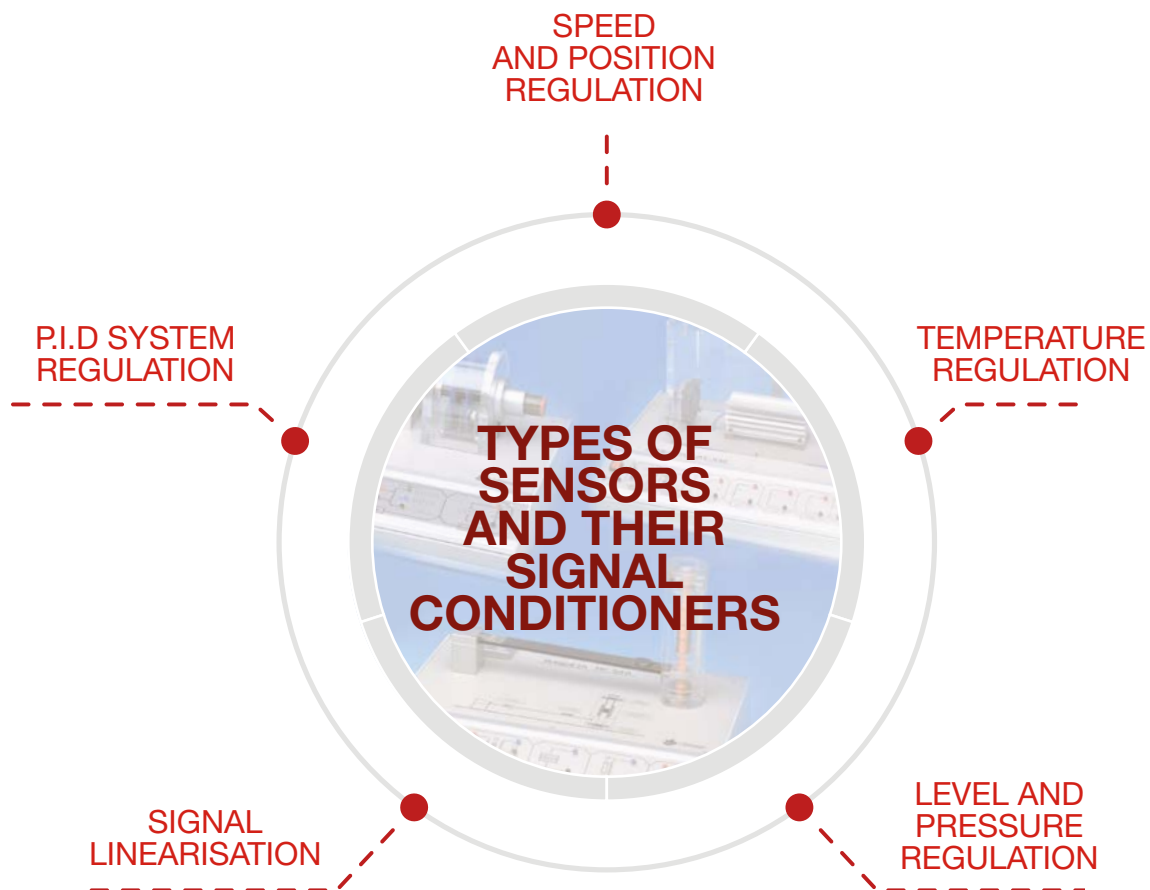

Simplicity

Process models with ready-to-work integrated actuators and sensors. 2 mm sockets for quick connection and multi-point measurement.

Quality

Compliant with the European low voltage and electromagnetic compatibility directives. Elements printed in accordance with the IEC (Electrotechnical Commission) standard.

Back-up resources

This equipment includes a set of back-up elements to aid the trainer, e.g.:

- Practical Manuals.
- Theory Manuals.
- Data collection and display software.
- Technical instruments, etc.

MODULAR PROGRAMME

The system is based on a “module” support, which can be configured according to user needs. The 540 series enables all the content to be studied, with high function integration on each module.

Assembly and power supply system

The basis of the modular programme consists of the assembly frame and the ± 15 V power supply module (ALI-700 module), which is required for all training module configuration requiring an electronic power supply.



107 /

Table-mounted training frame

- This is a physical support for the modules, blocks and panels used for the practical activities.
- It transmits the electrical supply from the power supply modules to all the modules requiring it.

The frame dimensions are selected in accordance with the equipment to be mounted on the frame. Its horizontal structure consists of an aluminium section and the rectangular side supports are oven-dried painted iron sections.

As regards locating the frame on the work tables, it may be fixed (the frame can be fixed to the tables) or mobile (in which case it is supplied with removable legs with non-slip feet). The module power supply and fixing systems consist of a series of connectors, into which the connection points located on the rear of the modules are inserted, exerting a slight pressure.

Ref.: 9EBxPxxCP

x: 1,2: frame height in tiers.
xx: 10, 14, 18, 20, 22, 28, 36, 44: n° of insertable single modules.

Training Module ALI-700

± 15 V. POWER SUPPLY

Power source: ± 15 V. It transmits the power supply via the table-mounted frame. These voltages are also available at 2 mm terminals.

It provides a nominal current of 2 A, and includes thermal and short circuit protection with automatic reset after a few seconds.

Ref.: MDULALI700

540 Series

Study of speed and position control processes

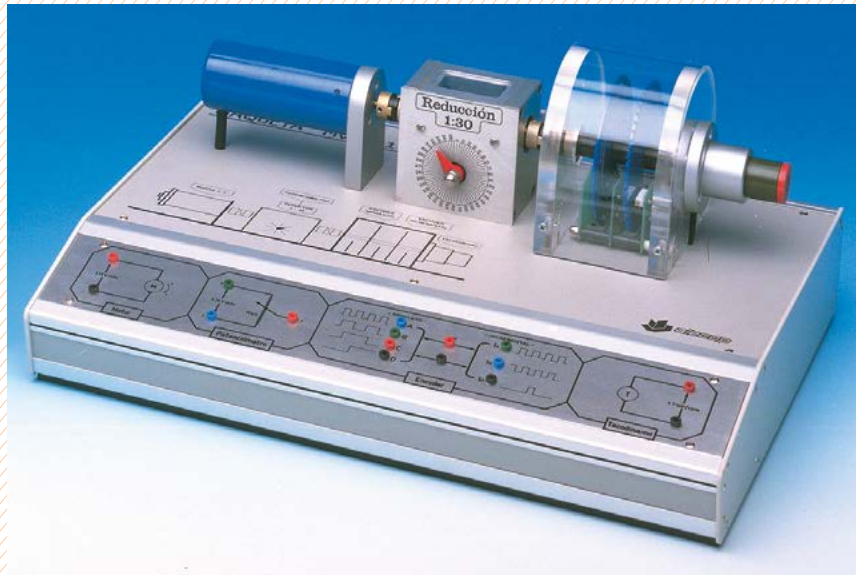

Ref.: 9EQCAMV541

108 /

Speed and position in a DC engine unit

MV-541

It consists of a model that incorporates a rotation axis powered by a DC motor, including the sensors, which are arranged in an accessible form to facilitate understanding by the student.

In associated with the motor axis, is available:

- A tacho speed for capturing.
- An absolute encoder and an incremental angular displacement uptake.
- A speed reducer indicating the angle of its axis reduced.
- A potentiometric angular position sensor.

The printed connection terminals are located on the front panel of the model, between the different sensors and the motor, with the conditioning and control models.

Standard components included:

- Table-mounted frame.
- ALI-700 power supply module.
- Series 540 model and specific control modules.

Standard accessories:

- Mains connection cable and 2 mm connectors.
- User Manual and Practical Manual.

Optional elements recommended:

- FPB training module: low pass filter.

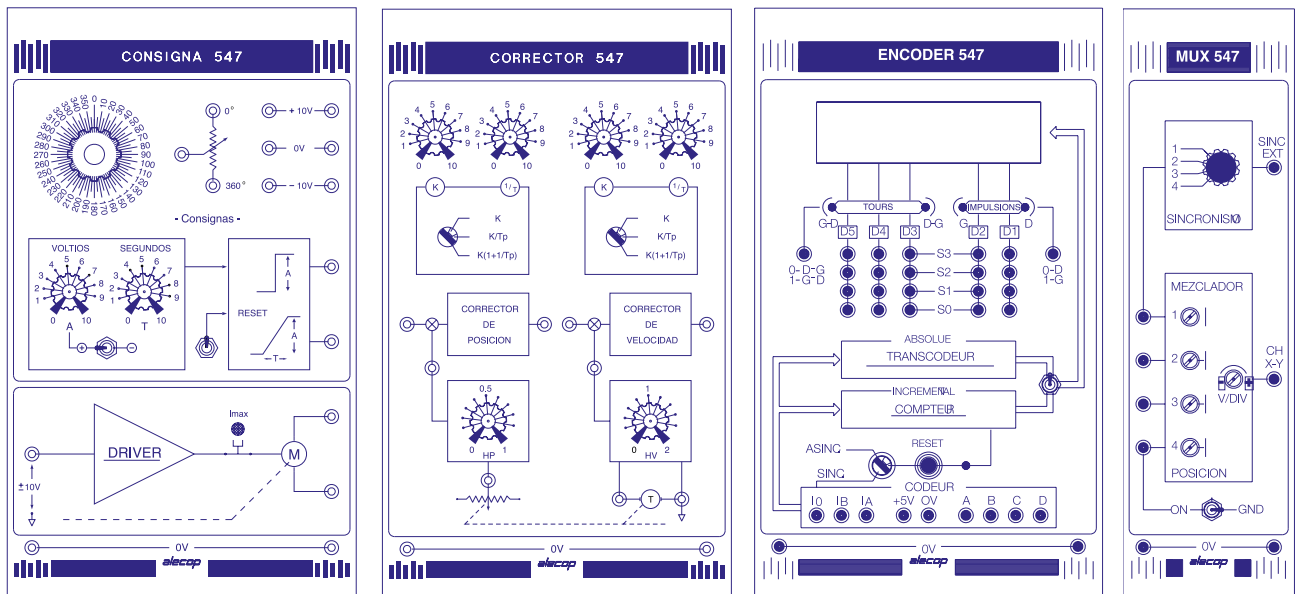

Encoder conditioner

ENCODER-547

- Display panel containing 7-segment displays of the number of pulses and turns from the absolute or incremental encoders.
- Pilot lights for right-left pulses and right-left or left-right turns, with their corresponding terminals.
- Terminals with BCD output for the value of each digit on the display.
- Selection of counter for incremental encoder and decoder for absolute encoder.
- Reset is manual or synchronised with the incremental encoder signal.

Speed and position corrector

CORRECTOR-547

- These are speed and position correctors which may be either proportional, integral or proportional-integral, selectable via rotary switch.
- Corrector parameters adjustable via potentiometric controls.
- Includes conditioners for the tacho dynamo and the potentiometric sensor.
- Includes analogue comparator and adder.

Setting and driver modules

CONSIGNA-547

- This contains the signal generator for the speed setting (step or ramp) and the position setting.
- Power driver acting on the DC motor, with overvoltage protection calibrated to 1 A.

4-channel multiplexer

MUX-547

- Enables up to four analogue and/or digital signals to be viewed on an oscilloscope.
- The four input channels have offset adjustment control and actuator switch or reset to zero.
- It is equipped with a selector switch for sync with respect to any of the inputs and another selector for alternate or chopped display.
- Outputs for connection to the oscilloscope channel and for connection to its external sync.

540 Series

Study of temperature control processes



Ref.: 9EQCAMT542

110 /

A furnace temperature unit

MT-542

The model consists of a simulator of a furnace in which are located inside the heating (equipped with aluminium radiator) and the different temperature sensors.

On the left side of the oven is located a fan whose window can be closed by a lid, available on the reverse side of a ventilation window also with a lid.

The sensors contained on the model are:

- 1 integrated temperature transducer AD-590.
- 1 type J thermo-couple.
- 1 positive temperature coefficient resistance transducer PTC.
- 1 platinum resistive transducer PT-100.

The last three sensors above are in heat contact with another three integrated transducers AD-590 installed,

and which serve as reference thermometers for these. Readings are taken from these transducers on the digital thermometer placed on the front panel of the model.

Printed connection terminals between the heater and the different sensors are included with the conditioning and control modules.

Standard components included:

- Table-mounted frame.
- ALI-700 power supply module.
- Series 540 model and specific control modules.

Standard accessories:

- Mains connection cable and 2 mm connectors.
- User Manual and Practical Manual.

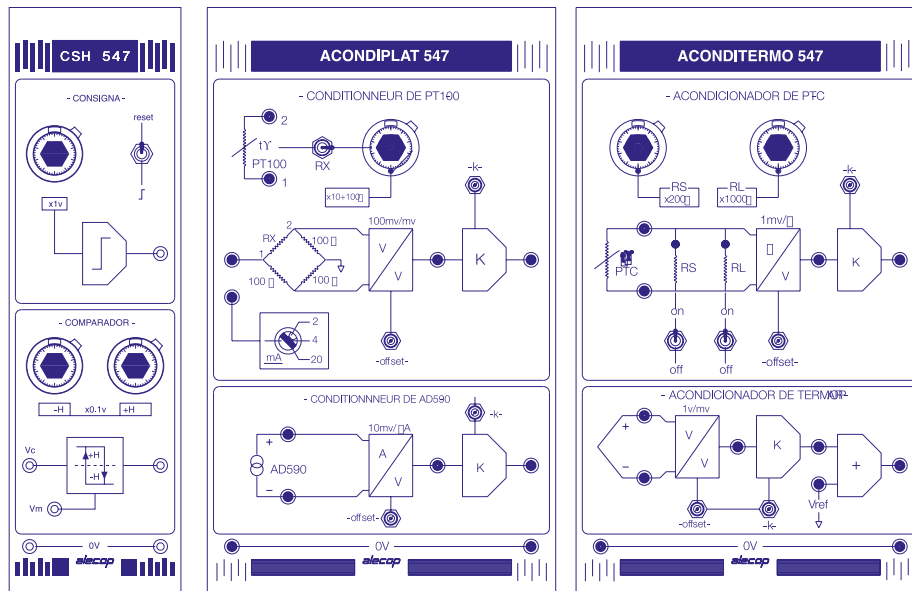

Set point and hysteresis control modules

CSH-547

- Set point signal generator, adjustable via potentiometric control.
- Comparator with hysteresis, with adjustable strip and pilot light indicating output level (0 or 1).

AD-549 and PT100 conditioner

CONDIPLAT-547

- Platinum resistance conditioner (PT100).
- AD-590 conditioner.
- Offset adjustment and gain controls.

Thermocouple and PTC conditioner

ACONDITERMO-547

- PTC temperature sensor and thermocouple conditioners.
- Offset adjustment and gain controls.

540 Series

Study of level processes and flow



Ref.: 9EQCAMD544

112 /

Level and flow of a deposit unit

MD-544

The model has a water-tight tank with two compartments, one to control the level and the other for drainage; there is a motorised pump which transfers the liquid from one place to another, and a set of sensors:

- For levels, using a float with linear potentiometer.
- For levels, by variable capacity.
- For levels, by ultrasound.
- For flow, by differences in hydrostatic pressure.
- For flow, by turbine.
- For hydrostatic pressure.

Printed connection terminals between the pump motor and the different sensors are included with the conditioning and control modules.

Standard components included:

- Table-mounted frame.
- ALI-700 power supply module.
- Series 540 model and specific modules.

Standard accessories:

- Mains connection cable and 2 mm connectors.
- Manual and Practical Manual.

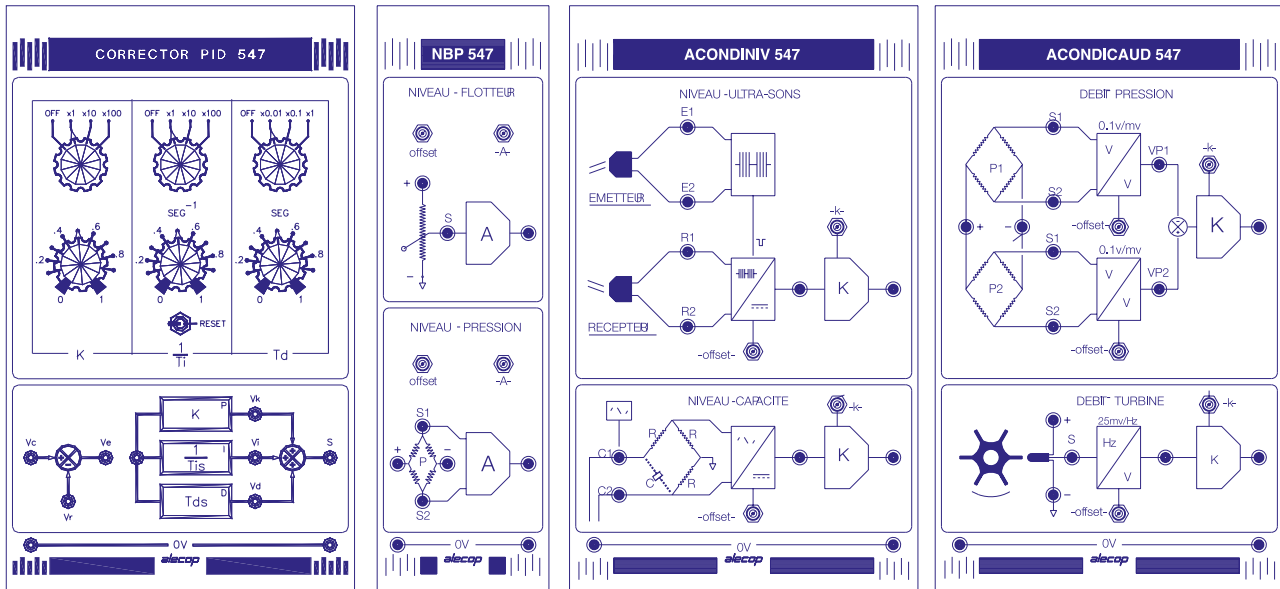

Setting and driver for pump motor modules

CSS-547

- Set point generator (adjustable ramp and step).
- Power amplifier for the motor pump.
- Overcurrent protection circuit calibrated to 1 A with automatic disconnection.

PID corrector

PID-547

- Adjustment of corrector parameter values via potentiometric controls.
- Selection of P, I, D correctors or any combination of the same.
- Reset switch.

Float and hydrostatic pressure conditioner

NBP-547

- Hydrostatic pressure sensor conditioner.
- Float type sensor conditioner.
- Offset and gain adjustment.

Flow conditioner

ACONDICAUD-547

- Pressure-difference flow sensor conditioner with offset and gain adjustment.
- Turbine flow sensor conditioner with frequency/voltage converter and gain adjustment.

Ultrasonic and capacitive level conditioner

ACONDINIV-547

- Ultrasonic level sensor conditioner with oscillator and offset and gain adjustment.
- Capacitive level sensor conditioner with oscillator and offset and gain adjustment.

540 Series

Study of physical magnitude sensors



Ref.: 9EQCAMF540

114 /

Physical measures unit

MF-540

The MF-540 unit is designed to make a real, practical study of physical magnitude sensors, such as movement, linear speed and acceleration and buckling forces on a plate.

The model is made up of a vibrating cantilever consisting of two plates firmly fixed at either end to a fixed mount on the model, and to a vertical rod. As collectors items containing:

- An LVDT (linear variation differential transformer) as the sensor for movement.
- An inductive speed sensor.
- A piezoelectric acceleration sensor.
- Four strain gauges, 2 working by traction and 2 by compression, to collect the buckling forces.

The drive device for the vibrating cantilever is a coil, which when excited by an oscillating signal, will make the cantilever vibrate.

The connecting terminals from the various sensors and the drive coil to the modular control cabinet is on the front panel.

Standard components included:

- Table-mounted frame.
- ALI-700 power supply module.
- Series 540 model and specific modules.

Standard accessories:

- Mains connection cable and 2 mm connectors.
- User Manual and Practical Manual.
- Micrometer.
- Weights.
- Allen key and adjustment screwdriver.

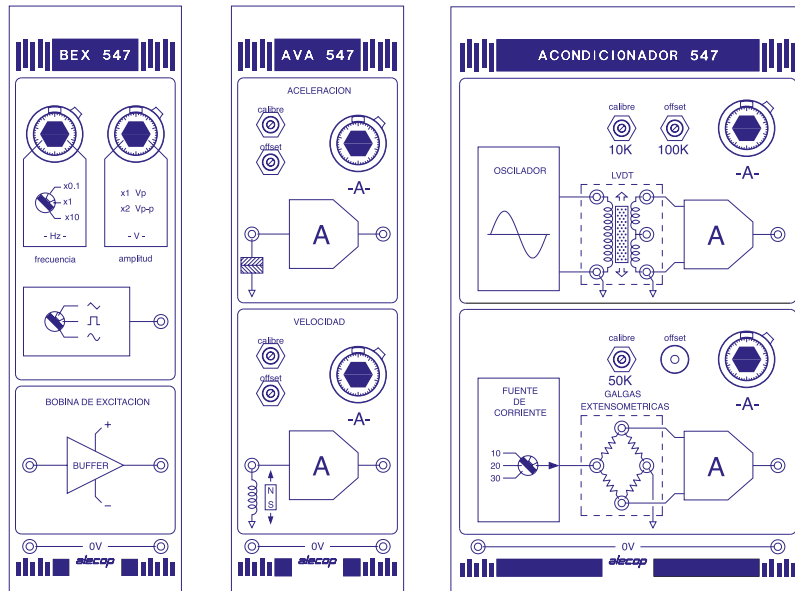

Oscillator coil driver modules

BEX-547

- Oscillator with variable amplitude and frequency, from 0 - 10 V and 0.1 Hz - 100 Hz.
- The signal is amplified by a current buffer providing up to 0.3 A.

Speed and acceleration conditioner

AVA-547

- Conditioners for the speed and acceleration sensor signals.
- Preamplifier and internal bandpass filter to eliminate mains noise.
- Adjustable amplifier and offset.

LVDT conditioner and gauges

ACONDICIONADOR-547

- Conditioners for displacement sensor signals (LVDT) and bending stresses (strain gauges).
- Adjustment controls for zero displacement and for calibre and gain for the LVDT.
- Gauge conditioner with rotary selector switch for setting Wheatstone bridge current.
- Controls for correction of offset and calibre and gain adjustment.

DAQ-601

Control module by Matlab/Labview

Control and data acquisition system. Module support for data acquisition, signals generation and digital control of processes. Programmable from MATLAB-SIMULINK, through the Data Acquisition Toolbox, and LABVIEW environment.



116 /

Technical characteristics

- Bus interface:
 - PC connection: USB serial port. No need to install cards in the computer. Allow to use laptops.
 - USB specification: USB Full Speed.
 - USB bus speed: 12Mb/s.
- Analog Inputs:
 - Channels: 8 single-ended / 4 differentials.
 - Input range: +/-10Vcc.
 - ADC resolution: 14 bits.
 - Bandwidth: 300 KHz.
 - Converter type: Successive approximation.
 - AI FIFO: 2,047 samples.
 - Trigger sources: Software, PFI 0, PFI 1.
 - Overvoltage protection.
- Analog Outputs:
 - Channels: 2.
 - DAC resolution: 14 bits.
 - Output range: +/-10V.
 - Maximum update rate: 5Ks/seg simultaneous per channel.
 - AI FIFO: 2,047 samples.
 - Trigger sources: Software, PFI 0, PFI 1.

- Digital I/O:
 - 13 digital lines.
 - 2 counter sources.
 - 2 digital triggers.
 - Direction control: each channel individually programmable as input or output.
 - Output driver type: each channel individually programmable as open collector or active drive.
 - 5V power source.

CD with documentation and software included:

- User manual and examples of control practical activities by Matlab and Simulink. These examples can be extended by the Matlab user, developing their own control algorithms.
- Graphical GUI user interfaces developed in Matlab to control 540 series models. These applications can be run from Matlab or through the included Runtime, without the need for Matlab.
- Use of the data acquisition toolbox for data acquisition and process control through Matlab and Simulink.

GUI user interfaces

Applications to be used by Matlab users or through facilitated Runtime, without the need for Matlab:

GUI_MV541: For dc motor speed and position control (using MV-541 model).

- Open Loop experiment.
- Closed loop speed control, PI controller.
- Closed loop position control, PID controller.

GUI_Level: For tank level control (using MD-544 model).

- On Off Control.
- Open loop experiment.
- Closed loop control, PID controller.

GUI_Flow: For tank flow control (using MD-544 model).

- Open Loop experiment.
- Closed loop control, PI controller.

GUI_MT-542: For temperature control (using MT-542 model).

- On Off Control.
- Open loop experiment.
- Closed loop control, PID controller.

117 /



Kaptoris

Data acquisition system



118 /

Versatile and powerful

Two features which make the KAPTORIS data acquisition system a general purpose tool indispensable for the analysis of teaching applications in laboratories of electricity, electronics, etc.

Team work

Using the KAPTORIS data acquisition system in a network facilitates group learning through tools, which allow:

- Teaching resources to be shared among several stations within the classroom: while one student captures the data, the others can analyse the obtained results.
- Carry out e-learning, on real units available in the classroom.

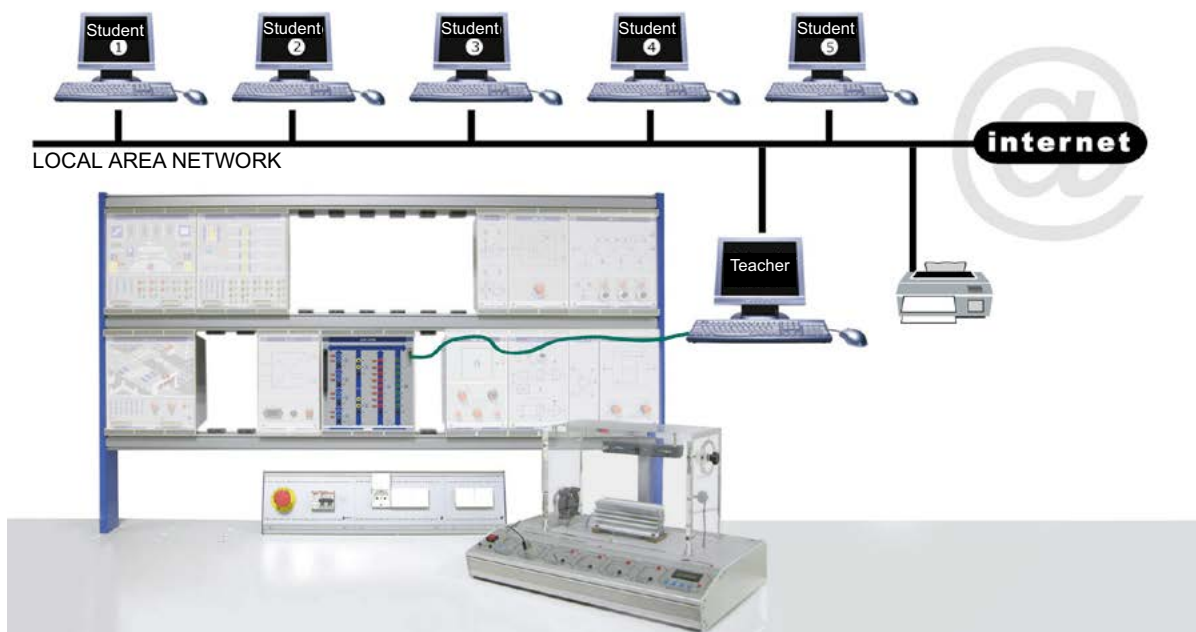

SAD450M (module)

The SAD450M has the same technical features as the SAD450 but is in module format, and facilitates data acquisition with Alecop units in module format.

A frame and an ALI700 mains supply source are needed to operate. These are not included with the unit.

Kaptoris software included.

MDULSAD450M

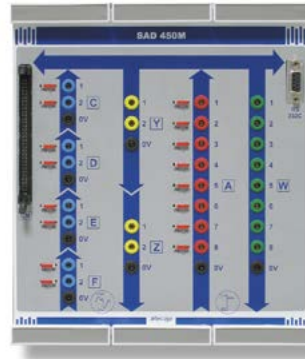

General purpose tool for acquiring, displaying and processing signals, both analogue and digital

Features of the software

- Simple data analysis, very easy to use.
- Graphic display of signals.
- Real time monitoring of the data as it is acquired.
- Programming by level or by time the start of the acquisition.
- Comparative analysis of signals.
- Operations between signals: Integration, derivation, arithmetical operations, filters.
- Generation of reports and data tables.
- Exporting data to TXT format.
- Exporting graphics to BMP, WMF format.
- Data acquisition from a unit with a remote connection through a local network. (Internet).
- Monitoring the screen of any PC connected to the network.

MINIMUM REQUIREMENT OF THE SYSTEM

- PC with Windows operating system.
- USB communication line.
- Local network, only if wishing to make remote acquisitions.

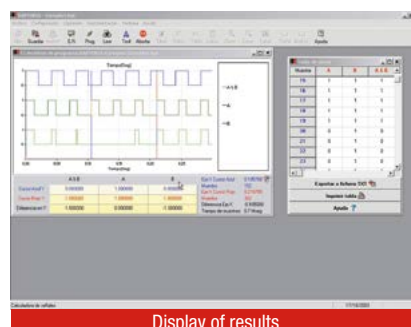
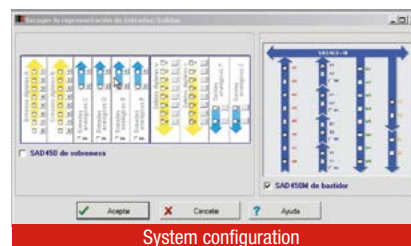

EN106

Computerized photovoltaic installation demonstrator

Simulates a photovoltaic system with real and didactic components controlled by computer.



120 /

The EN106 equipment scales a complete photovoltaic solar system. It has been designed with special emphasis on the didactic aspect of the same, being able to observe at a glance all the components that a solar photovoltaic installation has and its arrangement. It allows the study, of both isolated photovoltaic solar energy installations and grid connection.

It has cables ready to connect and disconnect the various elements of the installation in different ways, being able to observe and analyze the operation of the panels connected independently, in series, in parallel, with batteries in series or in parallel, with direct output in Direct current or direct current to AC converter, working in isle or connected to the grid.

It is provided with elements of measurement of the variables necessary to analyze the characteristics of the panels and their behavior. Thus, it has a pyranometer that indicates the intensity of radiation that affects the panels, with voltmeters and ammeters that show us respectively the voltage and the intensity generated.

It also has ammeter and voltmeter in each of the batteries to indicate the state of these and the direction of flow of the current in them, that is to say if they are loading or providing load, and also has a measuring instrument that provides us all the characteristics of the alternating current obtained after the inverter.

Learning objectives

- Study of the operation of a solar photovoltaic installation.
 - Isolated panels.
 - Panels connected to batteries.
 - Operating with different types of continuous loads.
 - Conversion of direct current to alternating current.
 - Operating with different types of alternating loads.
 - Operation in isle and network connection.
 - Installation performance.
 - Efficiency of the investors.
 - Representation through energy balance.
- Determination of the characteristics of solar panels.
 - Intensity curve – voltage at different temperatures.
 - Intensity of short circuit.
 - Voltage in open circuit.
 - Power curve – Voltage at different temperatures.
 - Power curve – Load resistance.
 - Maximum power generated.
 - Form factor.
 - Efficiency.
- Influence of the angle of inclination and the intensity of radiation in the generated energy.
- Determination of the characteristics of the panels connected in series or in parallel.
- Determination of the characteristics of the panels connected in parallel.
- Study of the behavior of solar panels in various operating conditions.
 - Isolated panels.
 - In parallel with different loads.
 - In series with different loads.
 - Panels connected to batteries in series.
 - In parallel with different loads.
 - In series with different loads.
 - Panels connected to batteries in parallel.
 - In parallel with different loads.
 - In series with different loads.
- Study assisted in PC.

Technical characteristics

- Panels: 2 photovoltaic panels of 20Wp.
- Control of temperature in the solar panels, to control the efficiency as a function of temperature.
- Cooling system of photovoltaic panels using fans.
- Regulation of the intensity of the lights, which simulate the sun.
- Battery charge controller: Regulator with 12 or 24V CC operation, and maximum current =10A. Maximum input voltage= 45V.
- Batteries: 2 Batteries of 12V 10Ah.
- Investors:
 - Sinusoidal inverter operating on Island 200 VA power, with 230V/50Hz output.
 - Inverter for network connection 230V/50Hz.
- Solar panel emulator module for connection to inverter for network connection, with solar intensity regulation.
- Pyranometer for the measurement of solar intensity.
- Rheostat for analysis of voltage-current graph in solar panels and comparison with specifications. It allows in series or parallel connection.
- Data acquisition card.
- The equipment is supplied with a complete workbook with its resolute version.
- Computer integrated in the computer with teaching software.

EN044

Insulated wind power plant trainer

Simulates an isolated wind installation with real and didactic components controlled by computer.

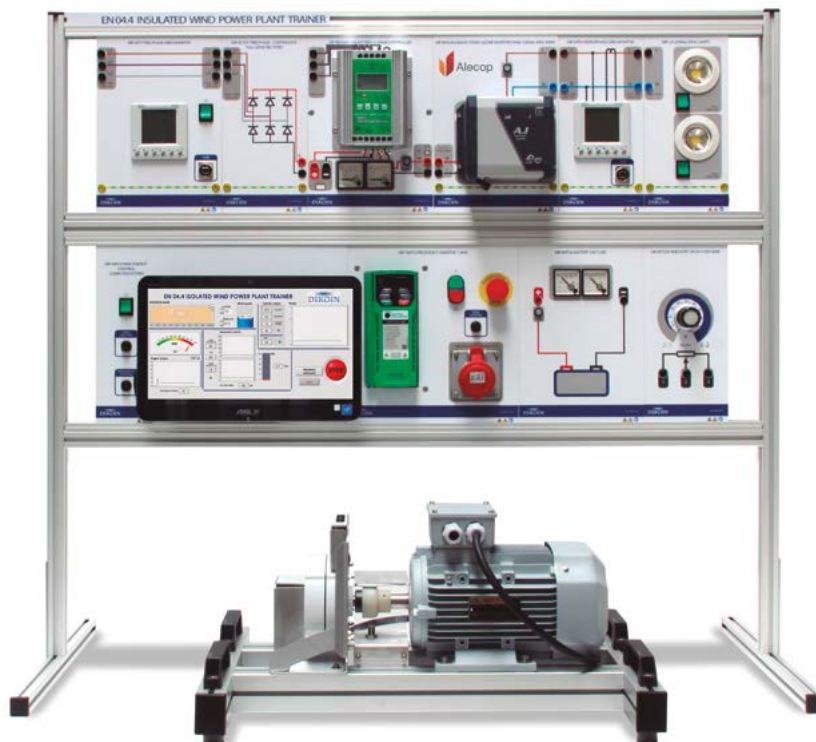

122 /

With the EN044 equipment, the behavior of a wind turbine is emulated in a practical and didactic way. An electric motor acts as the blades and bush of a wind turbine, dragging a three-phase synchronous generator of permanent magnets, which transforms the mechanical energy transmitted to the shaft into electrical energy at the output.

The current generated is alternating three-phase, having to transform into direct current to be able to feed the regulator of charge of batteries and consumptions, and later to the inverter that in turn turns this into alternating current with the appropriate frequency. So that the generated electric energy can be stored in batteries or consumed directly, or also use the stored charge for consumption when is no wind.

The equipment is designed to understood in a very visual and intuitive way quickly the operation of the assembly, not only knowing the elements of which it consists, but having them also to connect by means of the security cables supplied for that purpose. This is achieved by arranging the equipment in schematic and connectable panels.

In addition it counts on a computer from which we control the operation of the equipment and we obtain the reading of all the necessary variables for the analysis of the system.

Learning objectives

- Study of the operation and disposal of an isolated wind power generation system.
- Drawing of the characteristic curves of the generator:
 - Three-phase voltage depending on the speed of rotation.
 - DC voltage depending on the speed of rotation.
 - Torque based on the generated current.
 - Three-phase active power depending on the speed of rotation.
 - DC Power as a function of the speed of rotation.
 - Three-phase reactive power as a function of the speed of rotation.
- Calculation of the constant of torque/current and voltage / speed of rotation of the generator.
- Performance of the rectifier.
- Tracing of yield calculation curves: Electric power to the net/mechanical drag power.
- Determination of optimum operating points against variable atmospheric conditions.
- Tracing of the power-wind speed characteristic curve.

Technical characteristics

- Structure of anodised aluminum.
- Single-phase network analyzer with indication of active, reactive and apparent power, current, voltage, frequency, power factor, etc.
- Three-phase network analyzer with indication of active, reactive and apparent power, current, voltage, frequency, power factor, etc.
- Analog DC voltage and current indicators for 12V batteries and loads.
- Three-phase synchronous generator of permanent magnets.
- Battery Charge Controller: Regulator with operation 12 or 24V DC, and maximum current = 10A. Maximum input voltage = 45V.
- Battery of 12V 12Ah.
- Three phase full wave rectifier.
- Variable consumption rheostat.
- 2 AC lamps.
- 1.5 kW asynchronous motor.
- 200VA 230V/50Hz inverter.
- Frequency variator 1,5 kW.
- Data acquisition module.
- Computer with control and data acquisition software.
- The equipment is supplied with a complete experiments manual.

EN042

Grid connected windmill energy plant trainer

Simulates a wind power installation with real and didactic components controlled by computer.



124 /

With the equipment EN042, the behaviour of a wind turbine is emulated in a practical and educational way. An electric motor operates as the turbine on a windmill moving a three-phase synchronous permanent magnet generator, which converts the transmitted mechanical energy to electric energy.

The generated electricity is alternating current three-phase, having to be transformed into direct current to feed the inverter, which transforms it into alternating current at an appropriate frequency, and other necessary features to connect to the network.

The equipment is designed for a very visual and intuitive operation, quickly understand the functioning of the whole system, not just knowing the elements that compose the unit, but also having to connect them through the supplied cables for this purpose. This is achieved by the provision of equipment in modular panels. It also has a computer from which to control the operation of the equipment and get all the necessary variables for system analysis.

Learning objectives

- Study of the operation and components of a wind generation system connected to the mains.
- Plotting of the characteristic curves of the generator:
 - Three phase voltage according to the rotation speed.
 - Continuous voltage according to the rotation speed.
 - Torque according to the generated current.
 - Three phase active power according to the rotation speed.
 - DC power according to the rotation speed.
 - Three phase reactive power according to the rotation speed.
- Calculation of the “constant torque/current” and “voltage/generator rotational speed”.
- Rectifier efficiency.
- Performance curves calculation: “Electrical power to the mains/mechanical power”.
- Determination of optimum operating points under changing wind conditions.
- Drawing the “power/wind speed” curve.
- Analysis of the energy fed into the mains.

Technical characteristics

- Anodized aluminium structure.
- Phase network analyzer indicating active, reactive and apparent current, voltage, frequency, power factor, etc.
- Three-phase permanent magnet synchronous generator.
- 1.5 kW asynchronous motor.
- Networks connected Inverter 500 W (for 230V/50Hz., this can change depending on the country).
- 1.5 kW inverter.
- Protection module for connection to the mains.
- Data acquisition module.
- Computer with touch screen attached to the main control panel.
- The system is controlled with the computer (not only data acquisition).
- The unit is supplied with a comprehensive workbook.

EN041

Windmill test-bench

Simulates a test bench for wind turbines.



126 /

The Windmill Test-bench (EN041), is a wind tunnel of 2 meters length designed to work with windmills of less or equal to 630mm diameter. The equipment has a 612 mm windmill included, which has a torque and rotation speed measurement system.

The wind tunnel has a transparent part, so a complete sight of the windmill working is allowed. That part, can also be opened, to facilitate the access and manipulation of the system.

The tunnel has a built-in system for the measurement of the speed of the air by means of electronic pressure transducers, to monitor in real time the speed of the air that the windmill is put under.

The new system also has an electronic control of the pitch, to be modified from the control panel or from the computer.

All the system, is monitored and controlled through a control module, which also can be connected to a computer with a USB port.

Learning objectives

- Measurement of the power taken by the windmill.
- Determination of the characteristic curves of the power recovered by the windmill based on the wind speed.
- Determination of the coefficient of power of the windmill.
- Determination of the coefficient of power based on the specific speed.
- Obtaining of the coefficient of power based on the angle of pitch of the profile.
- Interchange of the blades of the windmill, for analysis of the variations based on the aerofoil profile.
- Modification of the pitch to see differences.

Technical characteristics

- Wind tunnel
 - Approximate length of the tunnel: 2 meters.
 - Maximum diameter of the windmill: 630mm.
 - Wind speed in the tunnel, adjustable from 0 to 13m/s.
 - Structure made of light weight anodized aluminum.
 - Vertically adjustable Legs for a correct level of the equipment.
 - Wheels for easy displacement of the equipment, 2 of them with brake.
 - Transparent polycarbonate part in the tunnel, with opening for access to the windmill.
- Windmill
 - Diameter of the rotor: 612mm.
 - Electronic sensor for measurement of rotation speed.
 - Load sensor for measurement of mechanical torque.
 - The pitch of the blades can be changed.
 - Possibility of modification of the pitch from the control module or software.
 - The blades can be replaced for different ones with 4 screws, without disassembling the windmill.
- Security
 - Security system that avoids the fan to start if the defense is open.
 - Protective grate in the suction bell, that avoids the frontal access (not shown).
 - Protective grate in the exit of air.
 - Emergency stop.
- Manual control panel
 - LCD display showing: brake power %, wind speed %, pitch %, turn speed of the windmill (rpm), wind speed (m/s) and mechanical torque in the windmill (Nm).
 - Potentiometer regulating the pitch of the wind turbine.
 - Potentiometer regulating the braking of the wind turbine.
 - Potentiometer regulating the air velocity in the tunnel.
 - Switch on or off the wind turbine braking system.
 - Control selector from control module, or from PC.
- ENS041 Control software (Optional)
 - Manual or automatic tests can be done, with only indicating the required variables and indicating how many points we want in the graph of results. This way we don't lose time writing the results and drawing the graphs by hand.
 - Automatic calibration system.
 - Wind speed control.
 - Windmill brake control with PID.
 - Automatic experiments varying the required parameter by the user autonomously, and recording data at each point.
 - The result can be shown in graphs and tables at the software, printed or exported to Excel.
 - It only needs a computer with a USB port and windows 7 or better.
 - Manual or automatic tests can be done, where the following values can be controlled and registered: Wind speed. turn speed of the turbine, torque of the turbine, etc.

EN051

Hydroelectric plant with Pelton turbine

Simulates a hydroelectric generation installation with real and didactic components.



128 /

Trainer EN051 has been designed as a small-scale hydropower plant and it is equipped with a Pelton-like turbine that provides full operation along with all the other accessories that complete a standard installation.

This training unit is composed of: a Pelton turbine, a water tank with a pump, a battery, a regulator, a current converter, a choice of charges both for DC and AC, a control panel, as well as voltage and current meters in key points in the installation circuit. Therefore, the unit enables students to observe and interpret accurately how a hydropower plants operates.

This training unit simulates the operation of a power generator, taking into account the hydraulic head of a reservoir, whereby potential water kinetic energy is transformed into electricity thanks to the operation of a turbine.

Additionally, the turbine is equipped with devices for measuring the motor torque and the rotational speed which enables calculations on mechanical energy retrieved and the mechanical and electric power efficiency rate.

Finally, there is a digital pressure transducer at the turbine inlet and a flowmeter which enable the calculation of hydropower output.

Learning objectives

- Turbine characteristic curves:
 - Torque – rotation speed (M-n).
 - Brake power – rotation speed (Pe- n).
 - Efficiency – rotation speed (h – n).
 - Torque – U (M-U).
 - Brake power – U (Pe- U).
 - Efficiency – U (h– U).
- Study of the operation of a hydraulic power installation.
 - Operation with different types of loads in continuous.
 - Conversion of direct current to alternating current.
 - Operation with different types of loads in alternation.
 - Installation efficiency.
- Determination of the electrical generation characteristics of the turbine, depending on the rotation speed.
 - Curve Intensity – Voltage.
 - Short circuit current.
 - Open circuit tension.
 - Power curve – Voltage.
 - Power curve – charge resistance.
 - Maximum power generated.
 - Form factor.
 - Efficiency.

Technical characteristics

- Pelton turbine with 16 blades, impeller diameter 124 mm and 1,900rpm.
- Pressure transducer.
- RPM detection sensor.
- Load cell for measuring torque.
- Electronic control module with two displays to show the system data.
- Battery charge regulator: Regulator with operation at 12 or 24V DC, and maximum current = 10A. Maximum input voltage = 45V.
- Battery: 12V 12Ah battery.
- Sinusoidal inverter operating on Island of 200 VA of power, with single-phase output.
- Analogue ammeter with positive and negative measurement (zero centered) and digital 4-digit with 12-bit resolution + sign.
- Panel of direct current lamps.
- Panel of alternating current lamps.
- Rheostat.
- Practice notebook.
- Possibility of connection to a computer via USB, to register all the data directly in tables.
- Power supply: 230V/Hz.

FL031

Series and Parallel Pumps

Simulates a hydraulic pump system and studies its behavior in series or parallel.



130 /

With this equipment you can practice much of the operations, start-up, operation and necessary regulations in a pump installation.

One of the pumps is controlled by a frequency variable, which allows varying the speed of rotation. Likewise, this pump has a measurement system of mechanical torque.

The flow rate is measured by an electronic flow meter.

In addition, you can make a study of the characteristics of a pump, working individually and in groups, in series or in parallel, performing a wide range of practices and experiences.

Learning objectives

- Start-up of a pump, analysis and study of different aspects to consider.
- Priming pump.
- Checking the sense of rotation.
- Over current produced in the engine.
- Study and obtain the characteristic curves of a pump.
 - Height – flow (H-Q).
 - Hydraulic power – flow (P-Q).
 - Torque – flow (M-Q).
 - Mechanical efficiency – flow (m-Q).
 - Mechanical power – flow (Pm – Q).
 - Efficiency of the engine – flow (e-Q).
 - Electric power – flow (Pe-Q).
 - Total efficiency – flow (-Q).
- Study of cavitation, and obtaining the N.P.S.H. Curve required-flow.
- Study of the different forms of regulating a pump. Checking similarity laws.
- Variation of the rotational speed. Obtaining the new characteristic curves.
- Changing the operating point by varying the pumping installation.
- Manoeuvred of the discharge valve.
- Analysis of the same and different pumps working in group.
- Characteristic curves operating in serie and parallel.
 - Height – flow (H-Q).
 - Power – flow (P-Q).
 - Efficiency – flow (-Q).

Technical characteristics

- Suction pipe diameters: internal 45.2 mm./external 50 mm.
- Drive pipe diameters: internal 45.2 mm./external 50 mm.
- Tank: 250 liters.
- Manometers:
 - Bourdon type with glycerin from –10 m.c.a. to 70 m.c.a.
 - Bourdon type with glycerin from –10 m.c.a. to 35 m.c.a. (x3)
- Pumps characteristics:
 - Manometric height 22 m.c.a.
 - Maximum flow 160 l/min. a 10 m.c.a.
 - Power consumed 750 W.
 - Rotational speed 2.900 r.p.m.
- Electronic flowmeter 1200-50000 l/h.
- Dynamometer 2 Kg x 10 gr.
- Wattmeters de 0 a 1200 W.
- Frequency variable 220V – 1,1 Kw.

AC031

Heat Pump Demonstration

Simulates a heat pump system and studies the utilization of ambient heat to heat water.



132 /

The AC031 equipment demonstrates clearly the operation of a heat pump air/water.

The system consists of: compressor, circulating pump, flow control valve, storage tank, condenser, filter/drier, expansion valve and evaporator fan, water flow meters, temperature sensors and pressure displays at strategic points circuit.

With this complete teaching unit, it can be studied with clarity the use of environmental energy to heat water.

The refrigerant absorbs ambient heat when passing through the evaporator with a fan, and subsequently transferred to the water in the condenser.

The hot water storage tank is equipped with an internal heat exchanger, which can be connected to the network, to exchange energy with the flow of water.

The heat absorbed by the water in the condenser, turn to hot water tank, where the heat energy can be exchanged with the flow of water.

The system is also ready to operate in open circuit, ie the mains water can enter directly to the condenser, which have instantaneous heating.

Technical characteristics

- R134a refrigerant.
- 533 W compresor/displacement: 6,1 cm³.
- Finned evaporator fan. Power: 380 W.
- Evaporator fan nominal speed 1500 rpm/airflow: 250 m³/h.
- Flowmeters scale: 35-350 l/h.
- Capacitor: exchanger concentric tubes.
- Hot water tank with internal heat exchanger, capacity: 5,5L.
- Circulation hot water circuit by circulator.
- Temperature sensors:
 - Input and output of the refrigerant to the condenser.
 - Input and output of the water to the condenser.
 - Input and output of the water to the coil.
- Pressure gauges: input and output of the refrigerant to the compressor.
- Flows: water flow through the condenser and through the coil of the accumulator.
- Working modes:
 - Heating with accumulation in the water tank.
 - Direct heating of water with the refrigerant-water exchanger.
- Requirements:
 - Input: 230V/50Hz.
 - Water supply.
 - Waste water connection.

Learning objectives

- Study of the operation of a heat pump.
- Study of the main components of the heat pump.
- Representation of reversible thermodynamic processes.
- Control of the temperatures and pressures in the process.
- Harnessing the accumulated heat.
- Energy balances:
 - Open circuit.
 - In closed circuit.

9 technical furniture



2200



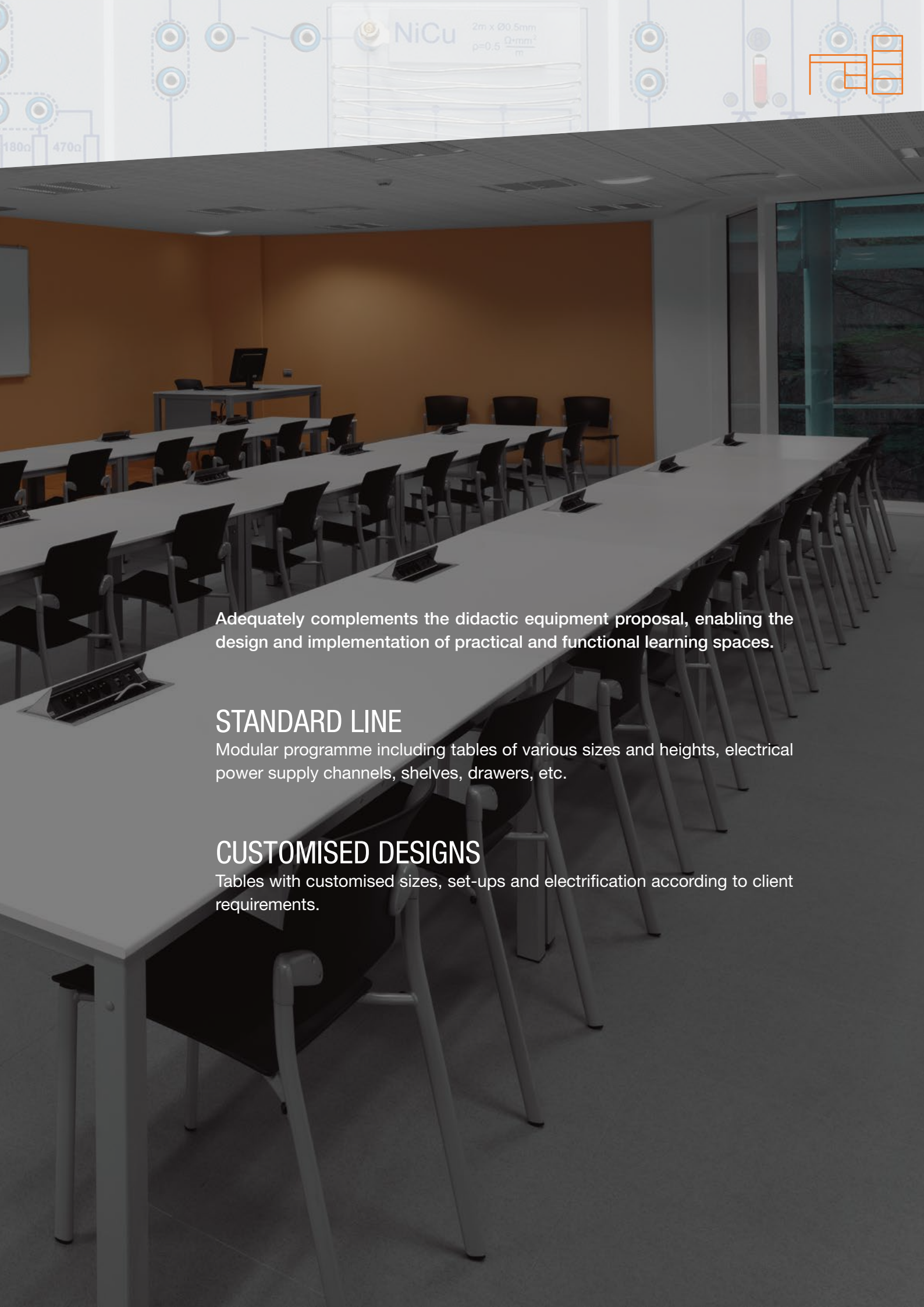

Adequately complements the didactic equipment proposal, enabling the design and implementation of practical and functional learning spaces.

STANDARD LINE

Modular programme including tables of various sizes and heights, electrical power supply channels, shelves, drawers, etc.

CUSTOMISED DESIGNS

Tables with customised sizes, set-ups and electrification according to client requirements.

Standard line



136 /

Functional

- Fixed tables or on wheels.
- Pre-drilled worktops for installation of accessories.
- Frame for teaching elements of various heights and lengths.

Modular electrification

- Channels of various lengths and with different protective and supply modules.
- Modular and extendible.

Robust

- Metal structures with epoxy paint.
- Worktops resistant to water, humidity and corrosive agents.
- Resistant to abrasion and to temperatures of up to 180 degrees.

Tables

Options: wheels, shelves, power supply channels, drawers, etc.



REFERENCE	MODEL
9EQBAN1569	Classroom/laboratory table with 1,500 x 800 mm worktop. Leg height 690 mm.
9EQBAN1587	Classroom/laboratory table with 1,500 x 800 mm worktop. Leg height 870 mm.
9EQBAN1869	Classroom/laboratory table with 1,800 x 800 mm worktop. Leg height 690 mm.
9EQBAN1887	Classroom/laboratory table with 1,800 x 800 mm worktop. Leg height 870 mm.

137 /

Power supply channels

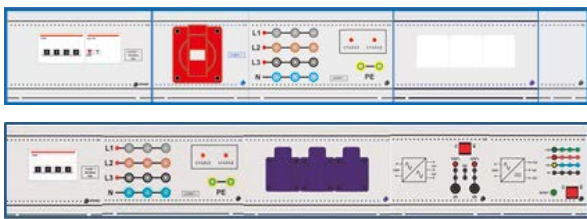

REFERENCE	9EQCA08H6Z	9EQCA12HCZ	9EQCA12HFZ
Model	230 Vac single-phase	230 Vac three-phase	380 Vac three-phase
Protection	Overload	Overload and earth leakage	Overload and earth leakage
230 Vac plug sockets	Yes (3 sockets)	Yes (3 sockets)	Yes (3 sockets)
Three-phase plug socket	No	Yes (1 socket)	Yes (1 socket)
Safety terminal sockets	Yes (L1, L2, PE)	Yes (L1, L2, L3, N, PE)	No
Length in mm.	624 mm	914 mm	914 mm



138 /

Table for electrical installations

- Work place for 4 students.
- Very solid structure in 50 x 50 x 2 mm steel pipe, painted with epoxy in grey.
- 35 mm thick white worktop in 2,000 x 1,000 mm thermolaminated agglomerate.
- Four removable 600 x 800 mm perforated mesh plates in bichromatised steel. Two additional meshes included.
- It has two mesh storage areas below the worktop.

The dual power supply system (one for each working face) has the following features:

- Four-pole start/stop general switch.
- Emergency stop button with key. Metal structure connected to earth.
- 24 Vac/2 A. source in sockets, protected 2 bornes, with switch and indicator light.
- Three phase multiple outlet in safety bornes.
- Voltage indicator lights and phase sequence.
- Two single-phase outlets of 230 Vac/10 A 2P+T.

Customised designs



Numeric Control Laboratory.
Metal Business Federation. MURCIA



Electrical Installation Laboratory.
COE MUHAYIL – ARABIA SAUDI

139 /



Electrical Automation Classroom.
COE ASIR – ARABIA SAUDI



Electricity Classroom.
ESCOLA FONSECA BENEVIDES – PORTUGAL



Computer Table.
SCHOOL PARK.
PORTUGAL



Computer Classroom.
CIFO LA VIOLETA – CATALONIA



www.alecop.com

Loramendi 11
20500 Arrasate-Mondragón
Gipuzkoa (Spain)
Tel: +34 943 71 24 05
alecop@alecop.es

